

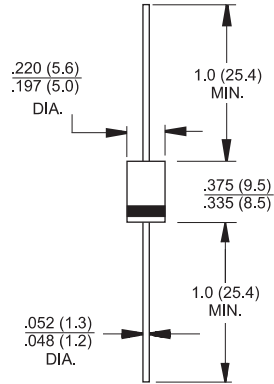

DO-201AD



Features

- ✧ Low power loss, high efficiency.
- ✧ High current capability, Low VF.
- ✧ High reliability
- ✧ High surge current capability.
- ✧ Epitaxial construction.
- ✧ Guard-ring for transient protection.
- ✧ For use in low voltage, high frequency inventor, free wheeling, and polarity protection application

Mechanical Data

- ✧ Cases: DO-201AD molded plastic
- ✧ Polarity: Color band denotes cathode
- ✧ High temperature soldering guaranteed: 260°C/10 seconds/.375", (9.5mm) lead lengths at 5 lbs., (2.3kg) tension
- ✧ Weight: 1.2 grams

Dimensions in inches and (millimeters)

Maximum Ratings and Electrical Characteristics

Rating at 25°C ambient temperature unless otherwise specified.

Single phase, half wave, 60 Hz, resistive or inductive load.

For capacitive load, derate current by 20%

Type Number	Symbol	SR 520	SR 530	SR 540	SR 550	SR 560	SR 590	SR 5100	SR 5200	Units
Maximum Recurrent Peak Reverse Voltage	V_{RRM}	20	30	40	50	60	90	100	200	V
Maximum RMS Voltage	V_{RMS}	14	21	28	35	42	63	70	140	V
Maximum DC Blocking Voltage	V_{DC}	20	30	40	50	60	90	100	200	V
Maximum Average Forward Rectified Current See Fig. 1	$I_{(AV)}$	5.0								A
Peak Forward Surge Current, 8.3 ms Single Half Sine-wave Superimposed on Rated Load (JEDEC method)	I_{FSM}	120								A
Maximum Instantaneous Forward Voltage @5.0A	V_F	0.55		0.70		0.85			V	
Maximum D.C. Reverse Current @ $T_A=25^\circ\text{C}$ at Rated DC Blocking Voltage @ $T_A=125^\circ\text{C}$	I_R	0.5			0.1			mA		
		15		10		5.0	1.0	mA		
Typical Junction Capacitance (Note 2)	C_j	250		210		120			pF	
Typical Thermal Resistance (Note 1)	$R_{\theta JA}$ $R_{\theta JC}$	35			10			$^\circ\text{C/W}$		
		2		2						
Operating Junction Temperature Range	T_J	-65 to +150								$^\circ\text{C}$
Storage Temperature Range	T_{STG}	-65 to +150								$^\circ\text{C}$

- Notes:
1. Mount on Cu-Pad Size 5mm x 5mm on P.C.B.
 2. Measured at 1 MHz and Applied Reverse Voltage of 4.0V D.C.

RATINGS AND CHARACTERISTIC CURVES

FIG.1- MAXIMUM FORWARD CURRENT DERATING CURVE

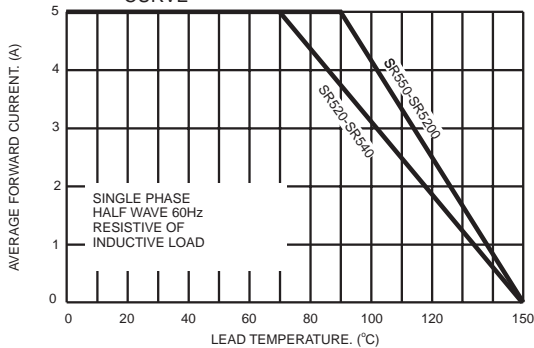

FIG.2- MAXIMUM NON-REPETITIVE FORWARD SURGE CURRENT

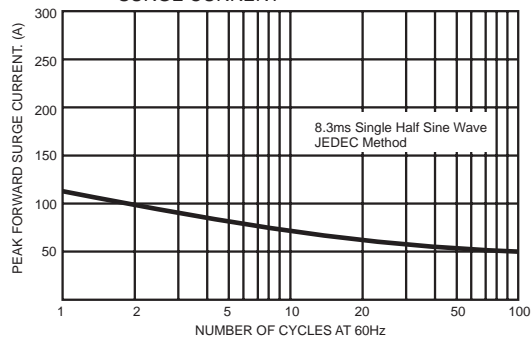

FIG.3- TYPICAL FORWARD CHARACTERISTICS

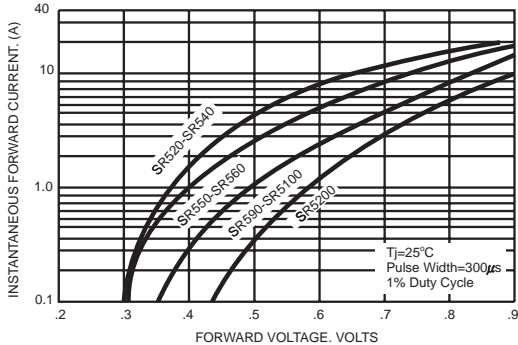

FIG.4- TYPICAL REVERSE CHARACTERISTICS

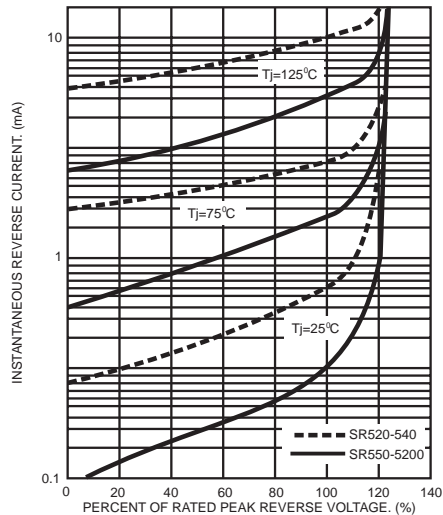

FIG.5- TYPICAL JUNCTION CAPACITANCE

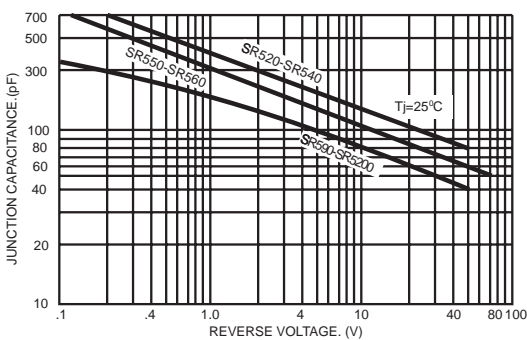
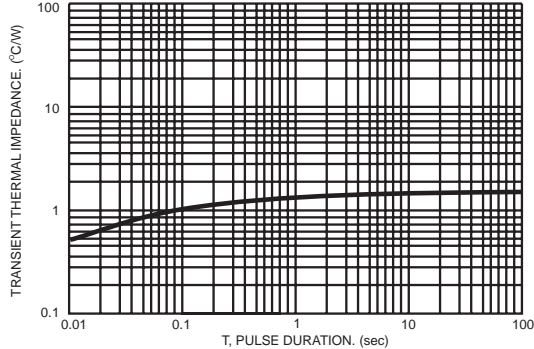

FIG.6- TYPICAL TRANSIENT THERMAL CHARACTERISTICS



Package Specifications

Case Style	Tape Pattern
A-405 R-1 DO-41 DO-15 DO-15L DO-15B R-3	<p> 6.0 ± 0.4 $52 \begin{smallmatrix} +1.5 \\ 0 \end{smallmatrix}$ 5 1.2max 1.0max 0.8max $L1-L2 \leq 0.8 \text{mm}$ </p>
DO-27S DO-27 R-6	<p> 6.0 ± 0.4 $52 \begin{smallmatrix} +1.5 \\ 0 \end{smallmatrix}$ 10 1.2max 1.0max 0.8max $L1-L2 \leq 0.8 \text{mm}$ </p>
A-405	<p> 6.0 ± 0.4 $36 \begin{smallmatrix} +1.5 \\ 0 \end{smallmatrix}$ 5 1.2max 1.0max 0.8max $L1-L2 \leq 0.8 \text{mm}$ </p>
A-405 DO-41	<p> 6.0 ± 0.4 $26 \begin{smallmatrix} +1.5 \\ 0 \end{smallmatrix}$ 5 1.2max 1.0max 0.8max $L1-L2 \leq 0.8 \text{mm}$ </p>

Package Specifications

1. SKETCH MAP OF PACKAGE

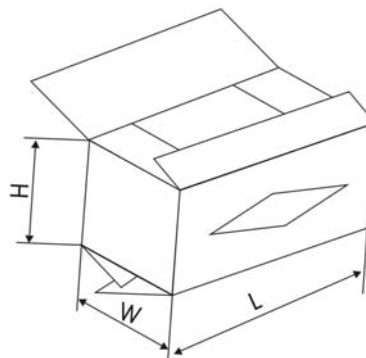
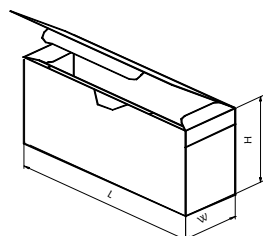

INNER BOX

CARTON

2.AMMUNITION PACKAGING (T/B)

PACKAGING CODE	CASE TYPE	INNER BOX				CARTON		APPROX WEIGHT (Kg)
		(K)	COMPONENT SPACE (mm)	TAPE SPACE (mm)	SIZE (mm ³)	(K)	SIZE (mm ³)	
HA	A-405	5	5	52	257x80x145	50	430x280x310	14
HB		2.5	5	52	255x75x75	50	400x270x340	20
HC	DO-41	5	5	52	257x80x145	50	430x280x310	20
HD		3.0	5	52	255x75x100	42	430x285x320	21
HE	DO-41(G)	2.5	5	52	265x75x75	100	440x270x340	21
HF	DO-15	2.0	5	52	255x75x100	28	430x285x320	14
HG	DO-15L/B	2	5	52	255x80x145	20	430x280x310	14
HH	DO-34(G)	5	5	52	255x75x75	100	440x270x340	18
HI	DO-35(G)	5	5	52	255x75x75	100	440x270x340	20
HJ	R-1	5	5	52	255x80x145	50	430x280x310	14
HK	R-3	2	5	52	255x80x120	20	430x280x260	17
HL	R-6	0.25	10	52	255x75x75	5	400x270x340	12
HR	DO-27	1.25	10	52	255x80x145	12.5	430x280x310	17
HM	A-405F	5	5	36	255x55x140	100	530x310x310	22
HN	A-405	2.5	5	26	255x55x75	70	400x270x340	14
HP	DO-41	2.5	5	26	255x55x75	70	400x270x340	14

SOLDER_REFLOW_PROFILE

Table 4-2 Pb-free Process – Package Classification Reflow Temperatures

Package Thickness	Volume mm ³ <350	Volume mm ³ 350 - 2000	Volume mm ³ >2000
<1.6 mm	260 +0 °C *	260 +0 °C *	260 +0 °C *
1.6 mm - 2.5 mm	260 +0 °C *	250 +0 °C *	245 +0 °C *
≥2.5 mm	250 +0 °C *	245 +0 °C *	245 +0 °C *

* Tolerance: The device manufacturer/supplier shall assure process compatibility up to and including the stated classification temperature (this means Peak reflow temperature +0 °C. For example 260 °C+0°C) at the rated MSL level.

Table 5-2 Classification Reflow Profiles

Profile Feature	Sn-Pb Eutectic Assembly	Pb-Free Assembly
Average Ramp-Up Rate (Ts _{max} to Tp)	3 °C/second max.	3° C/second max.
Preheat <ul style="list-style-type: none"> - Temperature Min (Ts_{min}) - Temperature Max (Ts_{max}) - Time (ts_{min} to ts_{max}) 	100 °C 150 °C 60-120 seconds	150 °C 200 °C 60-180 seconds
Time maintained above: <ul style="list-style-type: none"> - Temperature (T_L) - Time (t_L) 	183 °C 60-150 seconds	217 °C 60-150 seconds
Peak/Classification Temperature (Tp)	See Table 4.1	See Table 4.2
Time within 5 °C of actual Peak Temperature (tp)	10-30 seconds	20-40 seconds
Ramp-Down Rate	6 °C/second max.	6 °C/second max.
Time 25 °C to Peak Temperature	6 minutes max.	8 minutes max.

Note 1: All temperatures refer to topside of the package, measured on the package body surface.

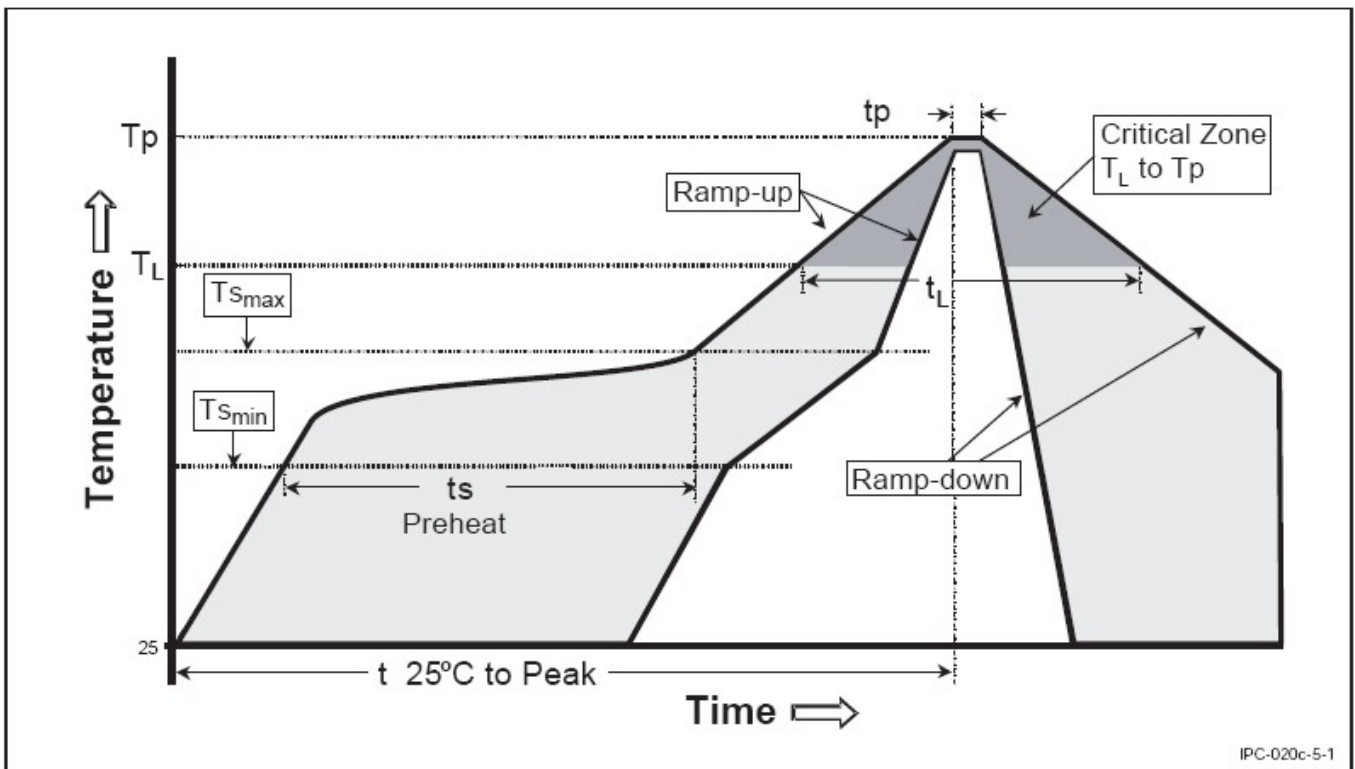

Figure 5-1 Classification Reflow Profile

Notice

MOSPEC reserves the rights to make changes of the content herein the document anytime without notification. MOSPEC or anyone on its behalf, assumes no responsibility or liability for any errors or inaccuracies. Please refer to MOSPEC website for the last document.

MOSPEC disclaims any and all liability arising out of the application or use of any product including damages incidentally and consequentially incurred.

Application shown on the herein document are examples of standard use and operation. Customers are responsible for comprehending suitable use in particular applications. MOSPEC makes no representation or warranty that such application will be suitable for the specified use without further testing or modification.

The information contained herein is presented only as a guide for the applications of our products. No responsibility is assumed by MOSPEC for any infringements of patents or other rights of the third parties which may result from its use. No license is granted by implication or otherwise under any patent or patent rights of MOSPEC or others.

These MOSPEC products are intended for usage in general electronic equipment. Please make sure to consult with MOSPEC before you use these MOSPEC products in equipment which require specialized quality and/or reliability, and in equipment which could have major impact to the welfare of human life (atomic energy control, aeronautics , traffic control, combustion control, safety devices etc.)