

40V P-Channel Power MOSFET

DESCRIPTION :

- Low on resistance
- Low reverse transfer capacitances
- 100% single pulse avalanche energy test
- 100% ΔV_{ds} Tested
- Low gate charge
- RoHS compliant

V_{DSS}	-40V
$I_D (T_C=25^\circ C)$	-50A
$R_{DS(ON_Typ. @V_{GS}=-10V}$	12m Ω

TYPICAL APPLICATIONS :

- Power switching applications
- DC-DC converters
- Full bridge control

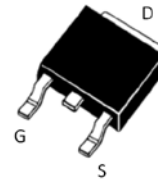

TO-252

MAXIMUM RATINGS (at $T_C = 25^\circ C$, unless otherwise specified)

Characteristic	Condition	Symbol	Value	Unit
Drain-Source Voltage		V_{DSS}	-40	V
Gate-Source Voltage		V_{GSS}	± 20	V
Continuous Drain Current	$T_C=25^\circ C$ $T_C=100^\circ C$	I_D	-50 -35	A
Pulsed Drain Current ⁽¹⁾		I_{DM}	-155	A
Single Pulsed Avalanche Energy ⁽²⁾		E_{AS}	289	mJ
Avalanche Current ⁽²⁾		I_{AS}	-34	A
Power dissipation	$T_A=25^\circ C$ $T_C=25^\circ C$	P_{tot}	1.6 82	W
Junction & Storage temperature Range		T_J, T_{STG}	-55~+150	$^\circ C$

- Notes : 1. Repetitive rating, pulse width limited by maximum junction temperature.
2. $L=0.5mH, I_{AS}=-34A, V_{DD}=-32V, V_{GS}=-10V, Start T_J=25^\circ C..$

THERMAL CHARACTERISTICS

Characteristic	Condition	Symbol	Value	Unit
Thermal resistance,	Junction to Ambient Junction to Lead	$R_{\theta JA}$ $R_{\theta JL}$	78.1 1.52	$^\circ C/W$

ELECTRICAL CHARACTERISTICS (at $T_c = 25\text{ }^\circ\text{C}$, unless otherwise specified)

Characteristic	Symbol	Min.	Typ.	Max.	Unit
Drain-Source Breakdown Voltage VGS = 0V, ID = -250uA	$V_{(BR)DSS}$	-40			V
Zero Gate Voltage Drain Current VDS = -40 V, VGS = 0 V	I_{DSS}			-1	uA
Gate-Source Leakage Current VGS = ± 20 V, VDS = 0V	I_{GSS}			± 100	nA
Gate-Source threshold voltage VDS = VGS, ID = -250uA	$V_{GS(th)}$	-1.1	-1.8	-2.5	V
Drain-Source On-State Resistance VGS = -10V, ID = -30A VGS = -4.5V, ID = -15A	$R_{DS(on)}$		12 20	15 25	m Ω
Gate Resistance VDD= 0 V, VGS= 0 V, f=1MHz	R_g		3.4		Ω
Input capacitance f=1MHz, VDS= -20 V, VGS=0 V	C_{iss}		2800		pF
Output capacitance f=1MHz, VDS= -20 V, VGS=0 V	C_{oss}		230		pF
Reverse transfer capacitance f=1MHz, VDS= -20 V, VGS=0 V	C_{rss}		180		pF
Total Gate Charge VDD= -20V, ID= -10A, VGS= -10V	Q_G		46		nC
Gate to Source Charge VDD= -20V, ID= -10A, VGS= -10V	Q_{GS}		12.2		nC
Gate to Drain Charge VDD= -20V, ID= -10A, VGS= -10V	Q_{GD}		6		nC
Turn-on delay time VDS= -20 V, VGS= -10V, ID= -10A, $R_D=3\Omega$	$t_{d(ON)}$		14		ns
Rise time VDS= -20 V, VGS= -10V, ID= -10A, $R_D=3\Omega$	t_r		53		ns
Turn-off delay time VDS= -20 V, VGS= -10V, ID= -10A, $R_D=3\Omega$	$t_{d(OFF)}$		45		ns
Fall time VDS= -20 V, VGS= -10V, ID= -10A, $R_D=3\Omega$	t_f		59		ns

Body Diode

ELECTRICAL CHARACTERISTICS (at $T_J = 25\text{ }^\circ\text{C}$, unless otherwise specified)

Characteristic	Symbol	Min.	Typ.	Max.	Unit
Diode Forward Voltage ⁽³⁾ VGS = 0V, I _S = -10A	V _{SD}			-1.2	V
Maximum Continuous Body Diode Forward Current	I _S			-45	A
Revers Recovery Time IF = -10A, dIF/dt = 100A/us	T _{rr}		23		ns
Revers Recovery Charge IF = -10A, dIF/dt = 100A/us	Q _{rr}		11		nC

Notes : 3. Pulse width $\leq 300\mu\text{s}$, duty cycle $\leq 2\%$.

Typical Performance Characteristics

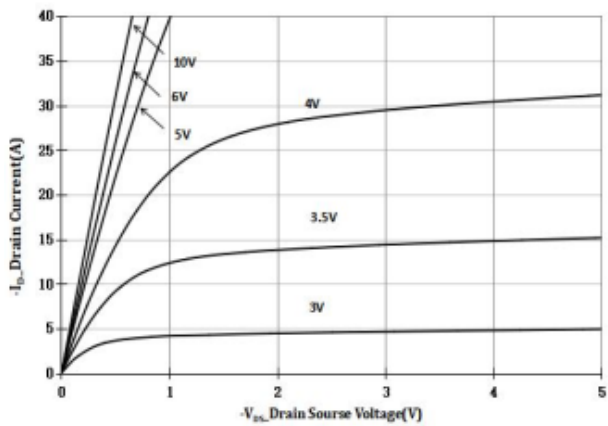

Figure 1 Output Characteristics

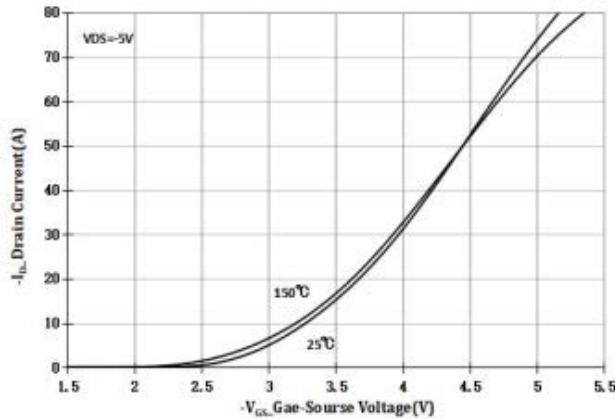

Figure 2. Transfer Characteristics

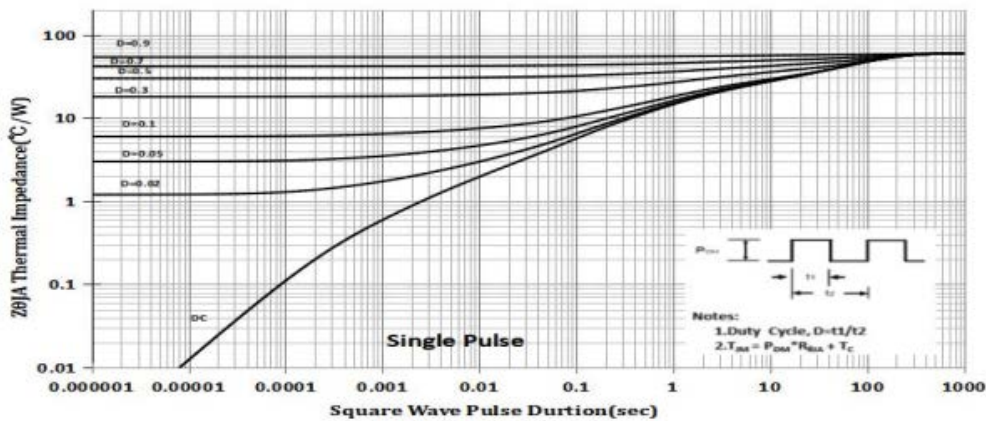

Figure 3. Normalized Maximum Transient Thermal Impedance

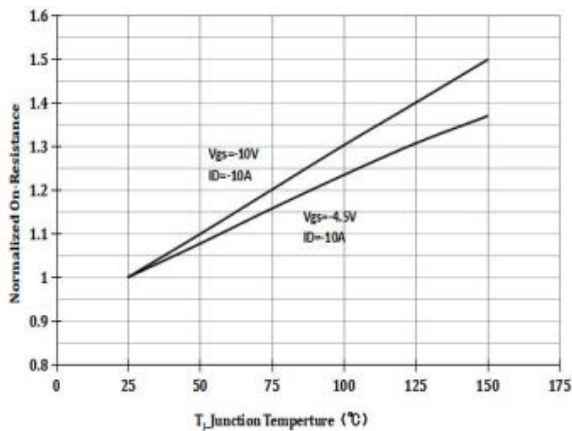

Figure 4. Rds(on) vs. Temperature

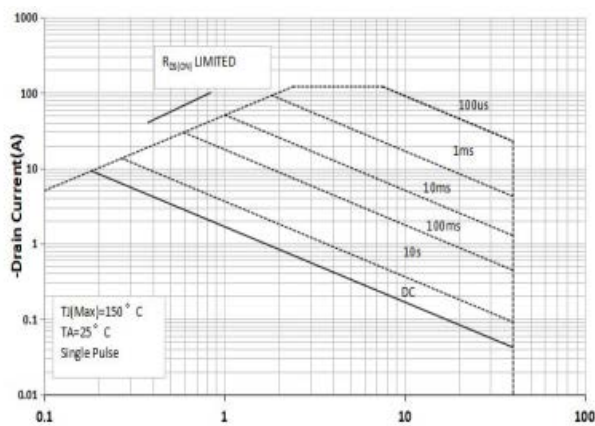

Figure 5. Safe Operating Area

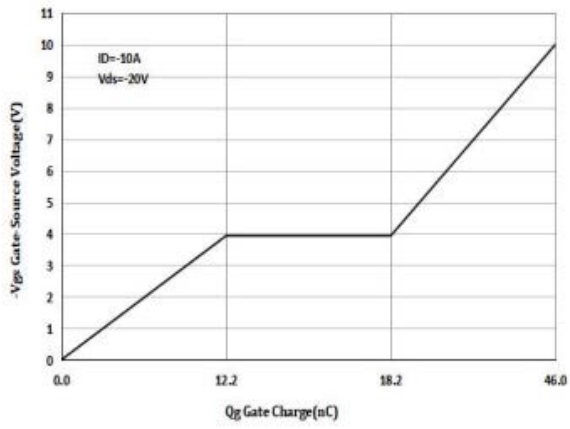

Figure 6. Gate Charge Characteristics

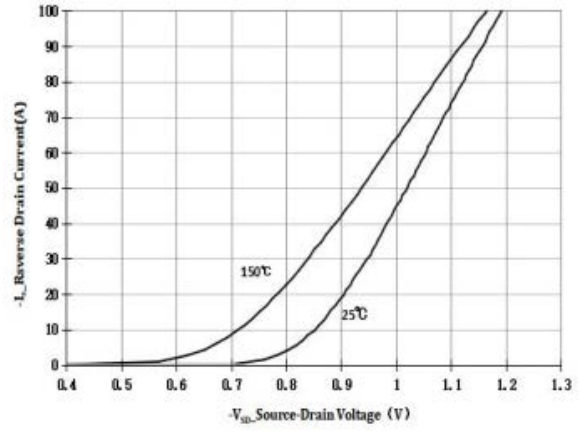

Figure 7. Body-diode Forward Characteristics

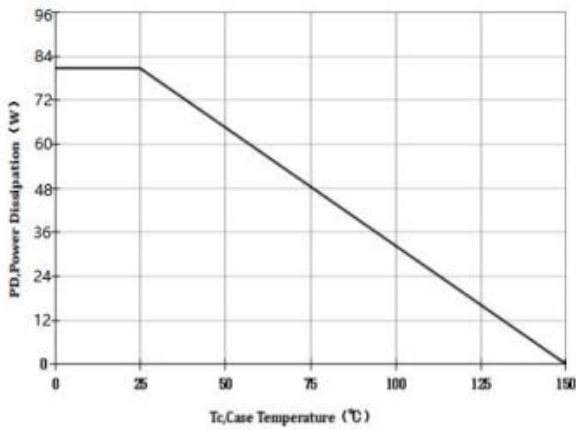

Figure 8. Power De-rating

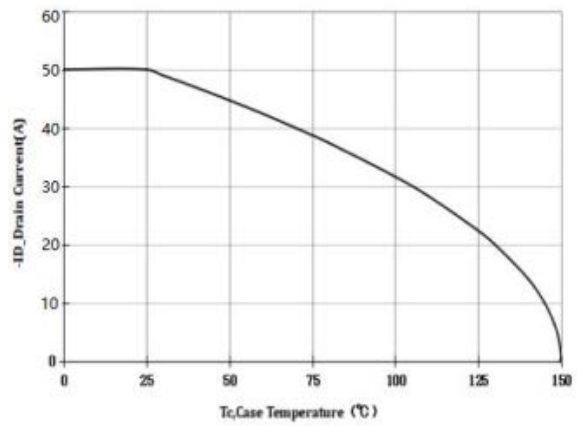

Figure 9. Current De-rating

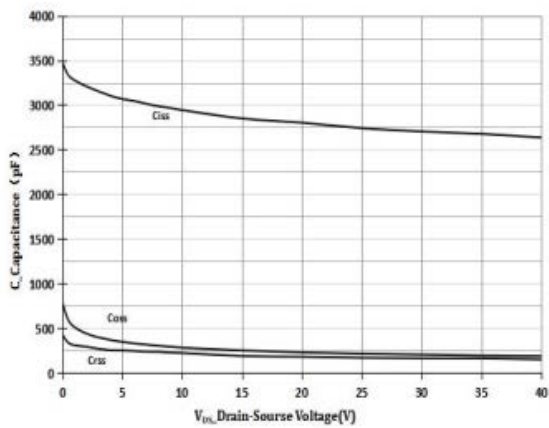
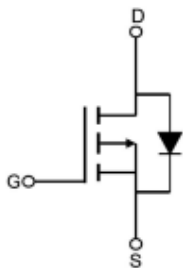
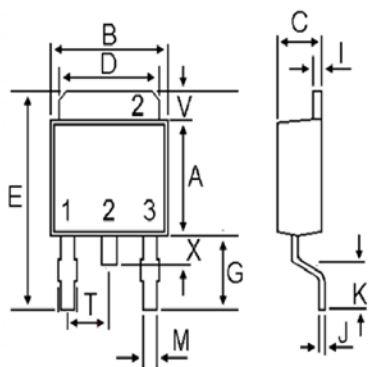

Figure 10. Capacitance vs Vds

- Circuit diagram



- Package outlines : Dimensions in (mm)



DIM	MILLIMETERS	
	MIN	MAX
A	5.97	6.22
B	6.30	6.75
C	2.18	2.40
D	4.95	5.50
E	9.40	10.41
G	2.75	3.20
I	0.46	0.89
J	0.46	0.61
K	1.40	1.78
M	0.64	0.89
T	2.18	2.38
V	0.89	1.27
X	---	1.05

Notice

MOSPEC reserves the rights to make changes of the content herein the document anytime without notification. MOSPEC or anyone on its behalf, assumes no responsibility or liability for any errors or inaccuracies. Please refer to MOSPEC website for the last document.

MOSPEC disclaims any and all liability arising out of the application or use of any product including damages incidentally and consequentially incurred.

Application shown on the herein document are examples of standard use and operation. Customers are responsible for comprehending suitable use in particular applications. MOSPEC makes no representation or warranty that such application will be suitable for the specified use without further testing or modification.

The information contained herein is presented only as a guide for the applications of our products. No responsibility is assumed by MOSPEC for any infringements of patents or other rights of the third parties which may result from its use. No license is granted by implication or otherwise under any patent or patent rights of MOSPEC or others.

These MOSPEC products are intended for usage in general electronic equipment. Please make sure to consult with MOSPEC before you use these MOSPEC products in equipment which require specialized quality and/or reliability, and in equipment which could have major impact to the welfare of human life (atomic energy control, aeronautics , traffic control, combustion control, safety devices etc.)