

## 30V N-Channel Power MOSFET

### DESCRIPTION :

- Excellent  $R_{DS(ON)}$
- Low Gate Charge
- 100% UIS Tested, 100%  $\Delta V_{DS}$  Tested
- Pb-Free Lead Plating
- RoHS compliant
- Halogen Free

$V_{DS}$	30V
$I_D @ V_{GS}=10V$	161A
$R_{DS(ON)_Typ.} @ V_{GS}=10V$	1.7m $\Omega$

### TYPICAL APPLICATIONS :

- Power Management
- Load Switch
- PWM Application

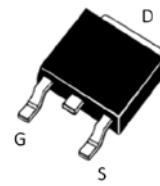

TO-252

### MAXIMUM RATINGS (at $T_C = 25^\circ C$ , unless otherwise specified)

Characteristic	Condition	Symbol	Value	Unit
Drain-Source Voltage		$V_{DS}$	30	V
Gate-Source Voltage		$V_{GS}$	$\pm 20$	V
Continuous Drain Current	$T_C=25^\circ C$ $T_C=100^\circ C$	$I_D$	161 102	A
Pulsed Drain Current <sup>(1)</sup>		$I_{DM}$	645	A
Single Pulsed Avalanche Energy <sup>(2)</sup>		$E_{AS}$	205	mJ
Power dissipation	$T_C=25^\circ C$	$P_D$	83	W
Junction & Storage temperature Range		$T_J, T_{STG}$	-55~+150	$^\circ C$

Notes : 1. Repetitive Rating: Pulse Width Limited by Maximum Junction Temperature.

2. This single-pulse measurement was taken under the following condition [ $L = 300 \mu H, V_{GS} = 10V, V_{DS} = 15V$ ] while its value is limited by  $T_{J\_Max} = 150^\circ C$

### THERMAL CHARACTERISTICS

Characteristic	Condition	Symbol	Value	Unit
Thermal resistance,	Junction to Ambient Junction to Case	$R_{\theta JA}$ $R_{\theta JC}$	50 1.2	$^\circ C/W$

ELECTRICAL CHARACTERISTICS (at  $T_J = 25\text{ }^\circ\text{C}$ , unless otherwise specified)

Characteristic	Symbol	Min.	Typ.	Max.	Unit
Drain-Source Breakdown Voltage VGS = 0V, ID = 1mA	$V_{(BR)DSS}$	30			V
Zero Gate Voltage Drain Current VDS = 24 V, VGS = 0 V	$I_{DSS}$			1	$\mu\text{A}$
Gate-Source Leakage Current VGS = $\pm 20\text{V}$ , VDS = 0V	$I_{GSS}$			$\pm 100$	nA
Gate-Source threshold voltage VDS = VGS, ID = 250 $\mu\text{A}$	$V_{GS(th)}$	1.2	1.6	2.5	V
Drain-Source On-State Resistance VGS = 10V, ID = 20A VGS = 4.5V, ID = 15A	$R_{DS(on)}$		1.7 2.2	2.2 2.9	m $\Omega$
Gate Resistance VDS=5V, ID = 20A	$g_{FS}$		110		S
Gate Resistance f=1MHz, VDS=0 V, VGS=0 V	$R_g$		1.8		$\Omega$
Input capacitance f=1MHz, VDS=15 V, VGS=0 V	$C_{iss}$		4185		pF
Output capacitance f=1MHz, VDS=15 V, VGS=0 V	$C_{oss}$		2861		pF
Reverse transfer capacitance f=1MHz, VDS=15 V, VGS=0 V	$C_{rss}$		233		pF
Total Gate Charge VDs= 15V, ID= 20A, VGS= 10V VDs= 15V, ID= 20A, VGS= 4.5V	$Q_G$		64 31		nC
Gate to Source Charge VDs= 15V, ID= 20A, VGS= 0 to 10V	$Q_{GS}$		10.4		nC
Gate to Drain Charge VDs= 15V, ID= 20A, VGS= 0 to 10V	$Q_{GD}$		9.7		nC
Turn-on delay time VDs=15 V, VGS= 10V, RL= 0.75 $\Omega$ , RGEN=6 $\Omega$	$t_{d(ON)}$		6.2		ns
Rise time VDs=15 V, VGS= 10V, RL= 0.75 $\Omega$ , RGEN=6 $\Omega$	$t_r$		7.8		ns
Turn-off delay time VDs=15 V, VGS= 10V, RL= 0.75 $\Omega$ , RGEN=6 $\Omega$	$t_{d(OFF)}$		35		ns
Fall time VDs=15 V, VGS= 10V, RL= 0.75 $\Omega$ , RGEN=6 $\Omega$	$t_f$		20		ns

## Body Diode

ELECTRICAL CHARACTERISTICS (at  $T_J = 25\text{ }^\circ\text{C}$ , unless otherwise specified)

Characteristic	Symbol	Min.	Typ.	Max.	Unit
Diode Forward Voltage $V_{GS} = 0V, I_S = 1A$	$V_{SD}$		0.69	1.0	V
Maximum Continuous Body Diode Forward Current	$I_S$			83	A
Revers Recovery Time $I_F = 15A, di/dt = 100A/us$	$T_{rr}$		54		ns
Revers Recovery Charge $I_F = 15A, di/dt = 100A/us$	$Q_{rr}$		60		nC

Typical Performance Characteristics

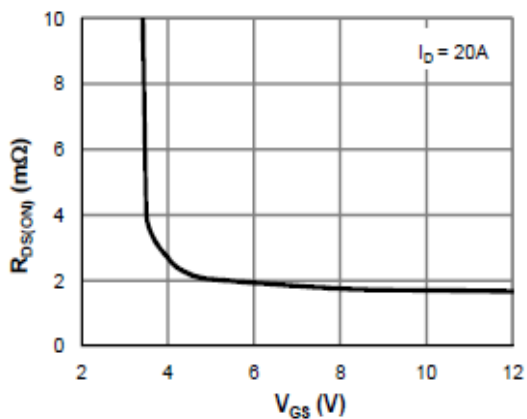

Figure 1.  $R_{DS(ON)}$  vs.  $V_{GS}$

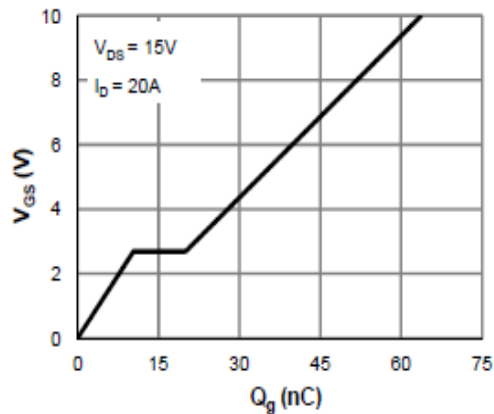

Figure 2. Gate Charge Characteristics

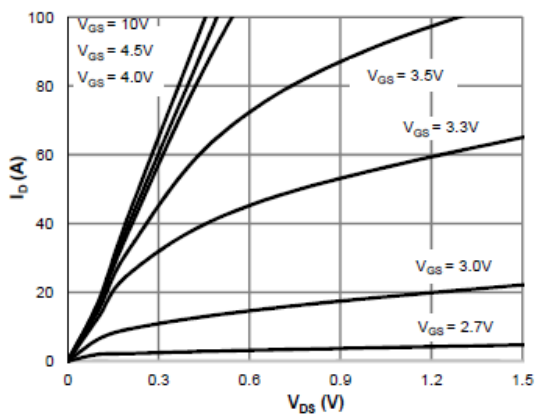

Figure 3. Saturation Characteristics

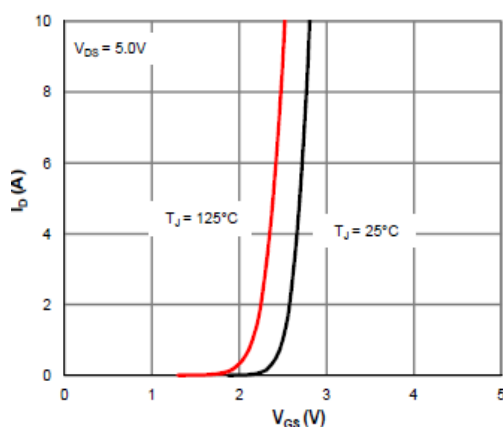

Figure 4. Transfer Characteristics

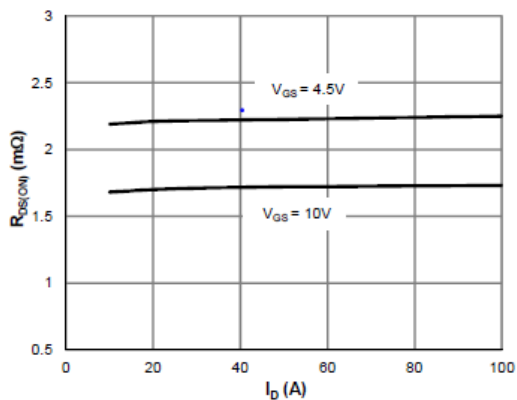

Figure 5. On-resistance vs. Drain Current

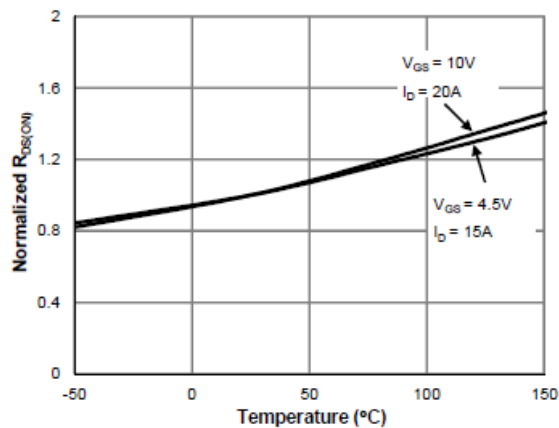

Figure 6.  $R_{DS(ON)}$  vs. Junction Temperature

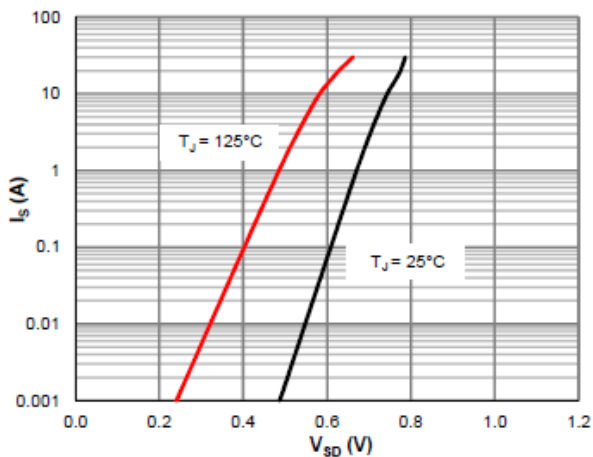

Figure 7. Body-Diode Characteristics

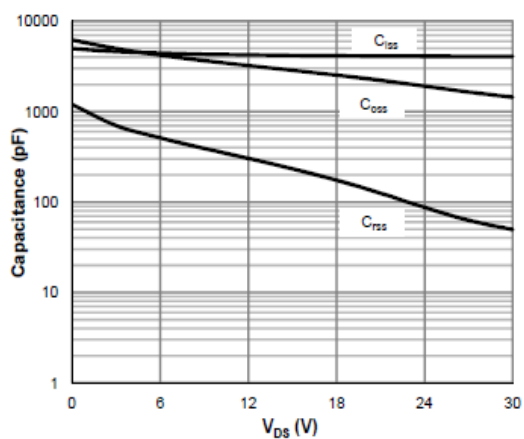

Figure 8. Capacitance Characteristics

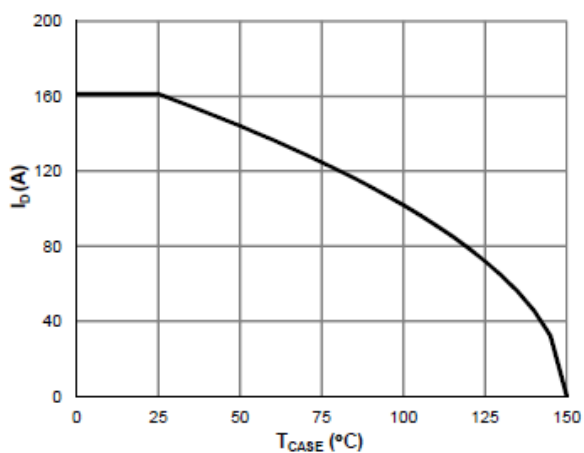

Figure 9. Current De-rating

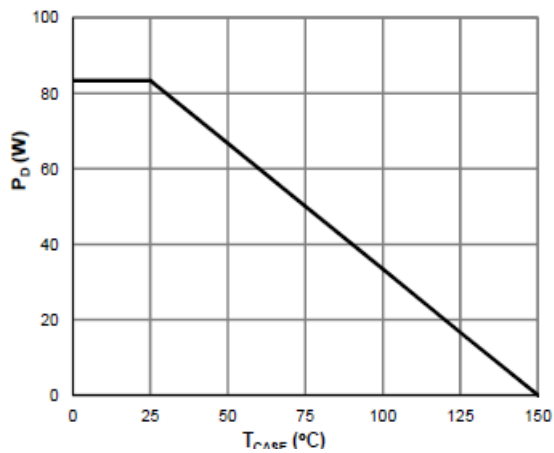

Figure 10. Power De-rating

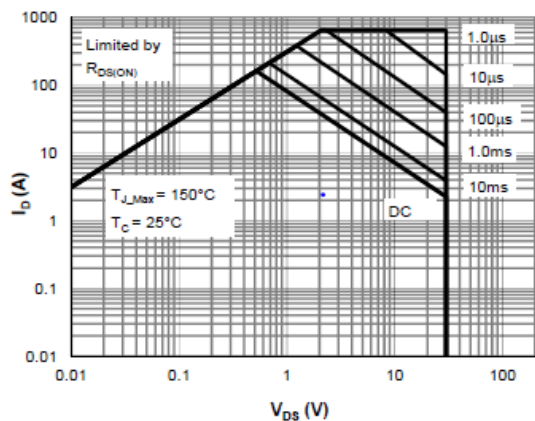

Figure 11. Single Pulse Power Rating, Junction-to-Case

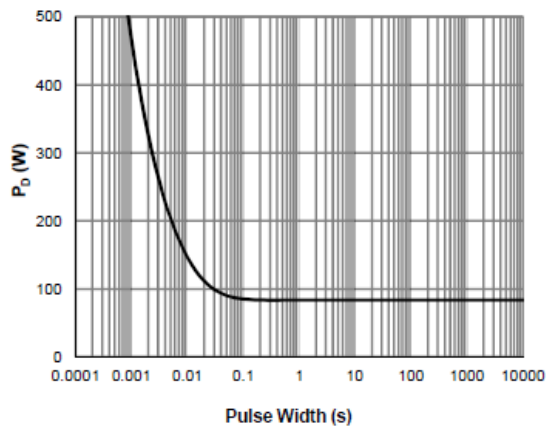

Figure 12. Maximum Safe Operating Area

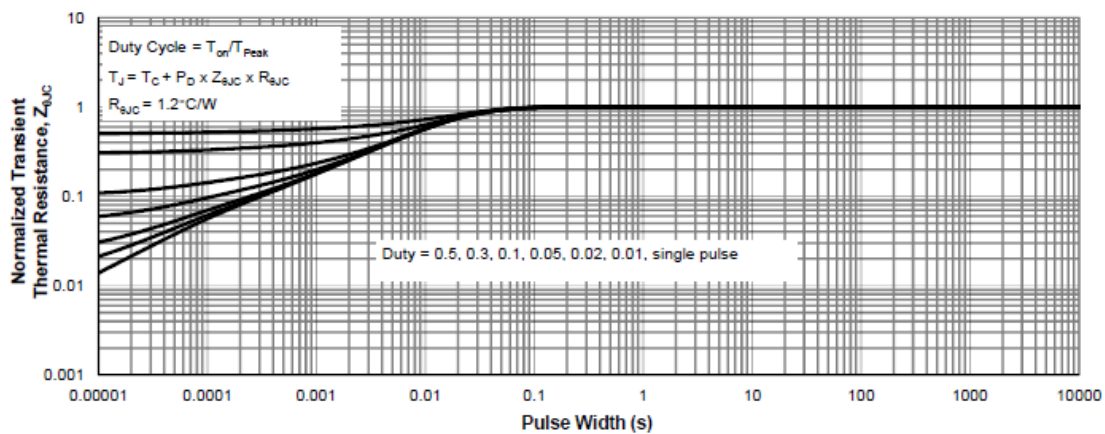
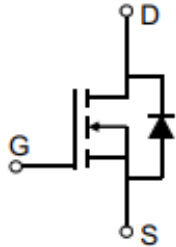

Figure 14. Normalized Maximum Transient Thermal Impedance

- Circuit diagram



- Package outlines : Dimensions in (mm)

**Package Outline Type-A**

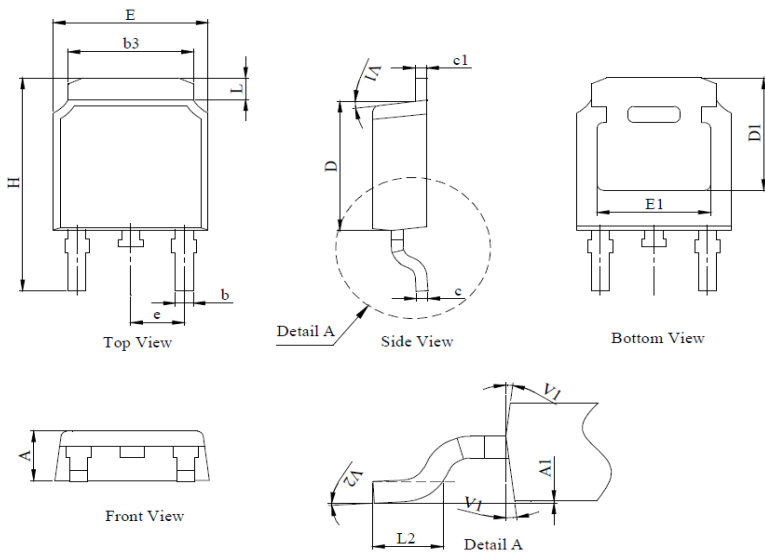

DIM.	MILLIMETER		
	MIN.	NOM.	MAX.
A	2.18	2.30	2.39
A1	0	--	0.13
b	0.64	0.76	0.89
c	0.40	0.50	0.61
c1	0.46	0.50	0.58
D	5.97	6.10	6.23
D1	5.05	--	--
E	6.35	6.60	6.73
E1	4.32	--	--
b3	5.21	5.38	5.55
e	2.29 BSC		
H	9.40	10.00	10.40
L	0.89	--	1.27
L2	1.40	--	1.78
V1	7° REF		
V2	0°	--	6°

**Package Outline Type-B**

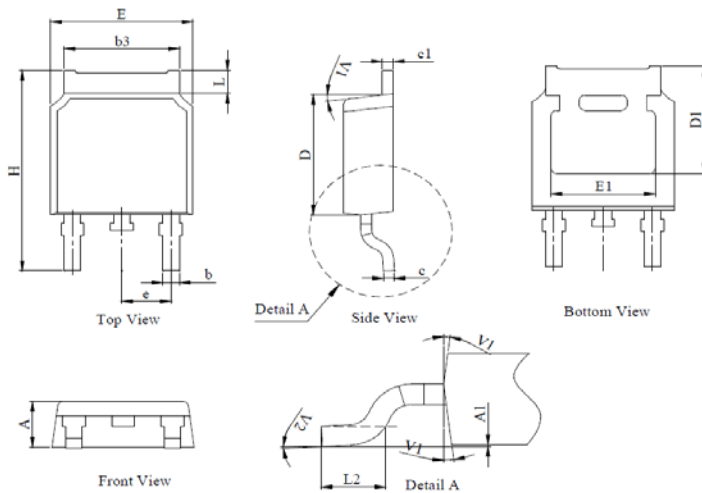

DIM.	MILLIMETER		
	MIN.	NOM.	MAX.
A	2.10	2.30	2.40
A1	0	--	0.13
b	0.66	0.76	0.86
b3	5.21	5.38	5.55
c	0.40	0.50	0.60
c1	0.44	0.50	0.58
D	5.90	6.10	6.30
D1	5.30REF		
E	6.40	6.60	6.80
E1	4.63	-	-
e	2.29 BSC		
H	9.50	10.00	10.70
L	1.09	--	1.21
L2	1.35	--	1.65
V1	7° REF		
V2	0°	--	6°

**Recommended Soldering Footprint**

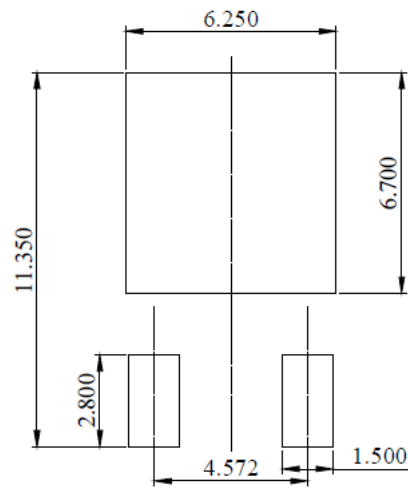

DIMENSIONS: MILLIMETERS

## Notice

MOSPEC reserves the rights to make changes of the content herein the document anytime without notification. MOSPEC or anyone on its behalf, assumes no responsibility or liability for any errors or inaccuracies. Please refer to MOSPEC website for the last document.

MOSPEC disclaims any and all liability arising out of the application or use of any product including damages incidentally and consequentially incurred.

Application shown on the herein document are examples of standard use and operation. Customers are responsible for comprehending suitable use in particular applications. MOSPEC makes no representation or warranty that such application will be suitable for the specified use without further testing or modification.

The information contained herein is presented only as a guide for the applications of our products. No responsibility is assumed by MOSPEC for any infringements of patents or other rights of the third parties which may result from its use. No license is granted by implication or otherwise under any patent or patent rights of MOSPEC or others.

These MOSPEC products are intended for usage in general electronic equipment. Please make sure to consult with MOSPEC before you use these MOSPEC products in equipment which require specialized quality and/or reliability, and in equipment which could have major impact to the welfare of human life ( atomic energy control, aeronautics , traffic control, combustion control, safety devices etc.)