

100V N-Channel Power MOSFET

DESCRIPTION :

- Ultra-Low On-Resistance, $R_{DS(ON)}$
- Low Gate Charge
- 100% UIS Tested, 100% Rg Tested
- Pb-Free Lead Plating
- RoHS compliant

V_{DS}	60V
$I_D @ V_{GS}=10V$	114A
$R_{DS(ON)_Typ.} @ V_{GS}=10V$	3.2m Ω

TYPICAL APPLICATIONS :

- Power Management
- Current Switch in DC/DC & AC/DC (SR) Sub-system
- Moto Driving in Power Tool, E-vehicle, Robotics

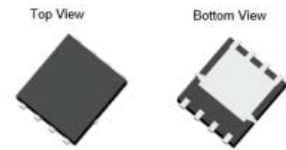

PDFN5x6-8L

MAXIMUM RATINGS (at $T_A = 25\text{ }^\circ\text{C}$, unless otherwise specified)

Characteristic	Condition	Symbol	Value	Unit
Drain-Source Voltage		V_{DS}	60	V
Gate-Source Voltage		V_{GS}	± 20	V
Continuous Drain Current	$T_c=25^\circ\text{C}$ $T_c=100^\circ\text{C}$	I_D	114 72	A
Pulsed Drain Current ⁽¹⁾		I_{DM}	411	A
Avalanche Energy ⁽²⁾		E_{AS}	182	mJ
Power dissipation	$T_c=25^\circ\text{C}$ $T_c=100^\circ\text{C}$	P_D	96 38	W
Junction & Storage temperature Range		T_J, T_{STG}	-55~+150	$^\circ\text{C}$

Notes : 1. Repetitive Rating: Pulse Width Limited by Maximum Junction Temperature.

2. E_{AS} of 182mJ is based on starting $T_J=25^\circ\text{C}$, $L=3.0\text{mH}$, $I_{AS}=11\text{A}$, $V_{GS}=10\text{V}$, $V_{DD}=30\text{V}$: 100% tested at $L=0.3\text{mH}$
 $I_{AS}=25\text{A}$

THERMAL CHARACTERISTICS

Characteristic	Condition	Symbol	Value	Unit
Thermal resistance,	Junction to Ambient Junction to Case	$R_{\theta JA}$ $R_{\theta JC}$	65 1.6	$^\circ\text{C}/\text{W}$

ELECTRICAL CHARACTERISTICS (at $T_J = 25\text{ }^\circ\text{C}$, unless otherwise specified)

Characteristic	Symbol	Min.	Typ.	Max.	Unit
Drain-Source Breakdown Voltage $V_{GS} = 0V, I_D = 250\mu A$	$V_{(BR)DSS}$	60			V
Zero Gate Voltage Drain Current $V_{DS} = 48V, V_{GS} = 0V$	I_{DSS}			1	μA
Gate-Source Leakage Current $V_{GS} = \pm 20V, V_{DS} = 0V$	I_{GSS}			± 100	nA
Gate-Source threshold voltage $V_{DS} = V_{GS}, I_D = 250\mu A$	$V_{GS(th)}$	1.2	1.8	2.5	V
Drain-Source On-State Resistance $V_{GS} = 10V, I_D = 20A$ $V_{GS} = 4.5V, I_D = 15A$	$R_{DS(on)}$		3.2 4.5	4.2 5.6	m Ω
Forward Transconductance $V_{DS} = 5V, I_D = 20A$	G_{FS}		35		S
Input capacitance $f = 1MHz, V_{DS} = 30V, V_{GS} = 0V$	C_{iss}		2405		pF
Output capacitance $f = 1MHz, V_{DS} = 30V, V_{GS} = 0V$	C_{oss}		1178		pF
Reverse transfer capacitance $f = 1MHz, V_{DS} = 30V, V_{GS} = 0V$	C_{rss}		50		pF
Gate Resistance $V_{DS} = 0V, V_{GS} = 0V, f = 1MHz$	R_g		4.3		Ω
Total Gate Charge $V_{DS} = 30V, I_D = 20A, V_{GS} = 10V$	Q_G		39		nC
Gate to Source Charge $V_{DS} = 30V, I_D = 20A, V_{GS} = 0$ to 10V	Q_{GS}		18.7		nC
Gate to Drain Charge $V_{DS} = 30V, I_D = 20A, V_{GS} = 0$ to 10V	Q_{GD}		7.3		nC
Turn-on delay time $V_{DS} = 30V, V_{GS} = 10V, R_L = 1.5\Omega, R_{GEN} = 3\Omega$	$t_{d(ON)}$		8.9		ns
Rise time $V_{DS} = 30V, V_{GS} = 10V, R_L = 1.5\Omega, R_{GEN} = 3\Omega$	t_r		29		ns
Turn-off delay time $V_{DS} = 30V, V_{GS} = 10V, R_L = 1.5\Omega, R_{GEN} = 3\Omega$	$t_{d(OFF)}$		44		ns
Fall time $V_{DS} = 30V, V_{GS} = 10V, R_L = 1.5\Omega, R_{GEN} = 3\Omega$	t_f		22		ns

Body Diode

ELECTRICAL CHARACTERISTICS (at $T_J = 25\text{ }^\circ\text{C}$, unless otherwise specified)

Characteristic	Symbol	Min.	Typ.	Max.	Unit
Diode Forward Voltage $V_{GS} = 0V, I_S = 1A$	V_{SD}		0.7	1.0	V
Diode Continuous Current, $T_c=25^\circ\text{C}$	I_S			96	A
Revers Recovery Time $I_F=20A, dI_F/dt = 100A/\mu s$	T_{rr}		38		ns
Revers Recovery Charge $I_F=20A, dI_F/dt = 100A/\mu s$	Q_{rr}		28		nC

Typical Performance Characteristics

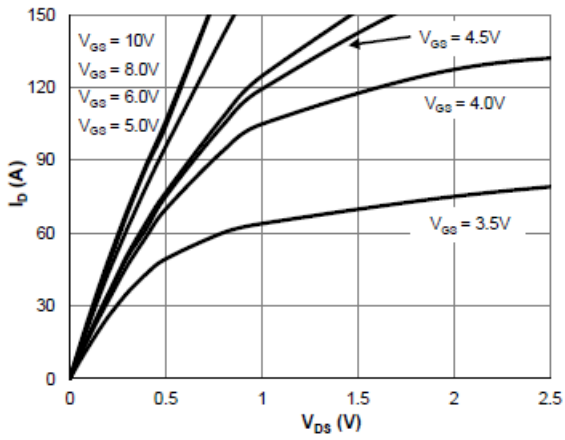

Figure 1. Output Characteristics

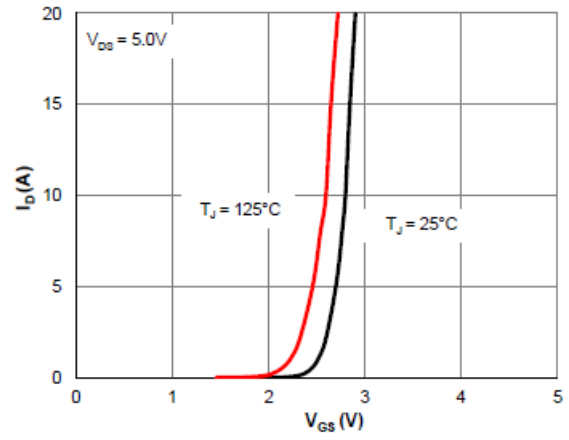

Figure 2. Typical Transfer Characteristics

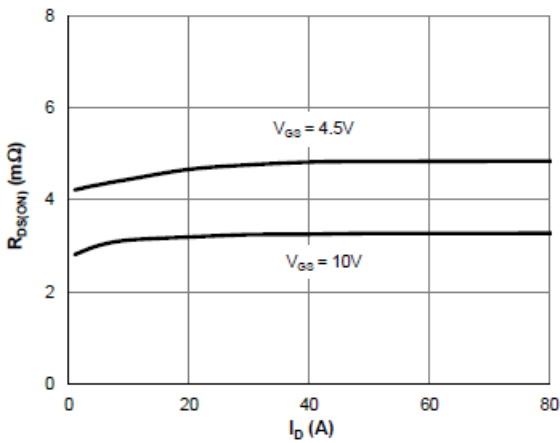

Figure 3. On-resistance vs. Drain Current

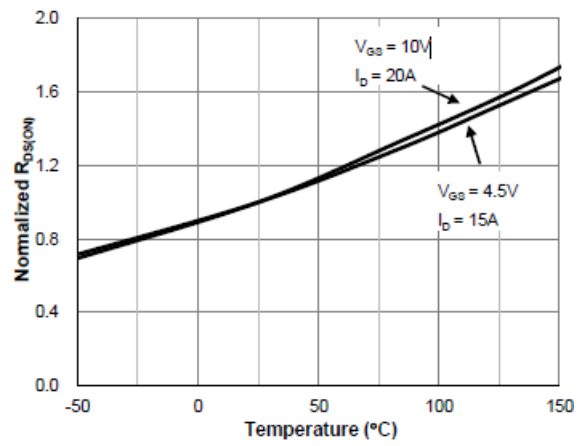

Figure 4. Normalized on Resistance vs. Junction Temperature

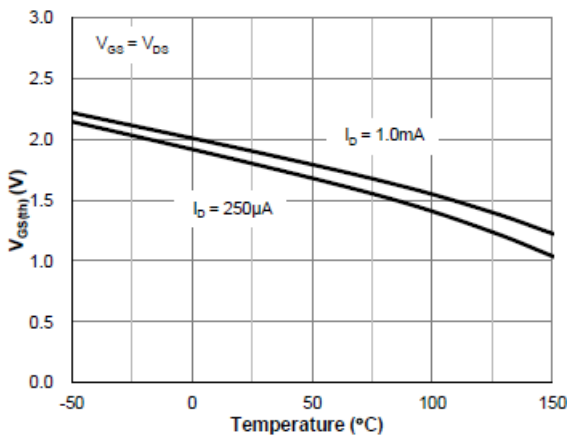

Figure 5. $V_{GS(th)}$ vs. Junction Temperature

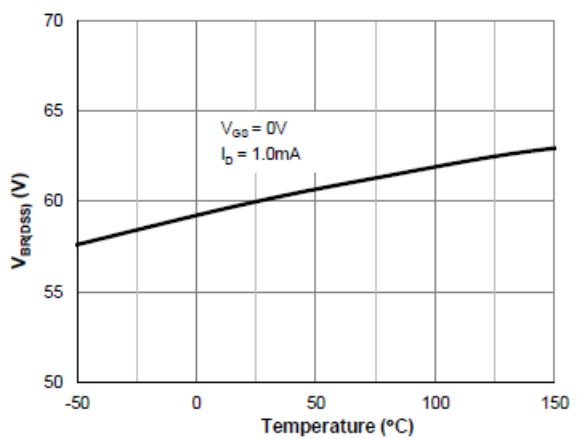

Figure 6. $V_{BR(DSS)}$ vs. Junction Temperature

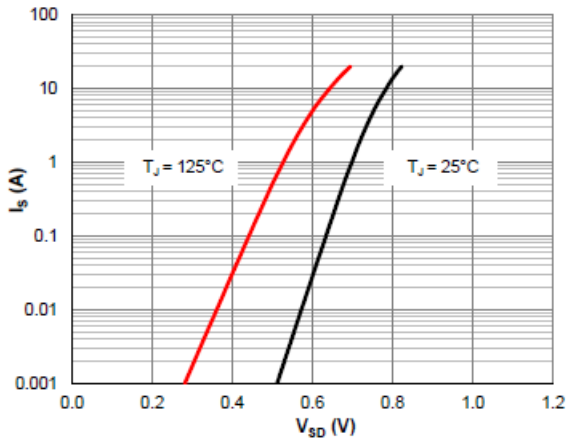

Figure 7. Body Diode Characteristics

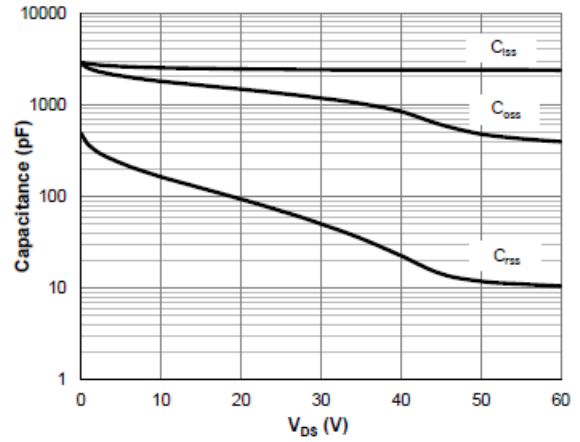

Figure 68 Capacitance Characteristics

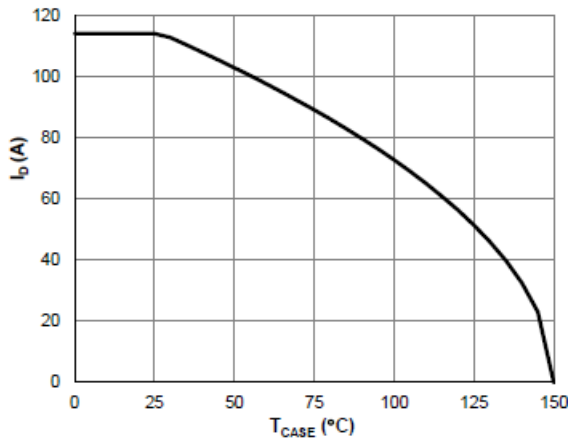

Figure 9. Current De-rating

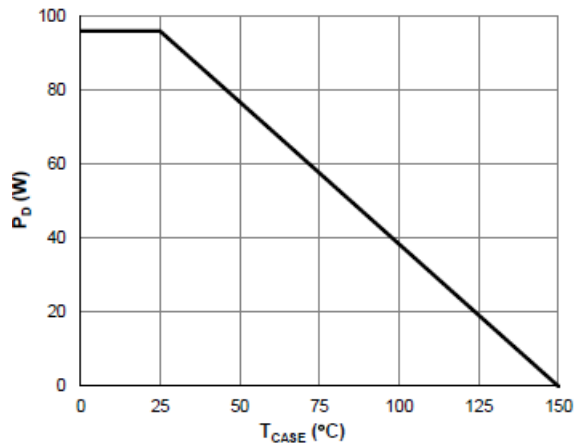

Figure 10. Power De-rating

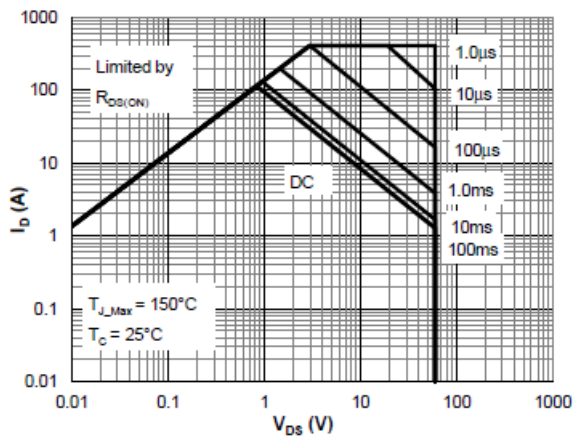

Figure 11. Maximum Safe Operating Area

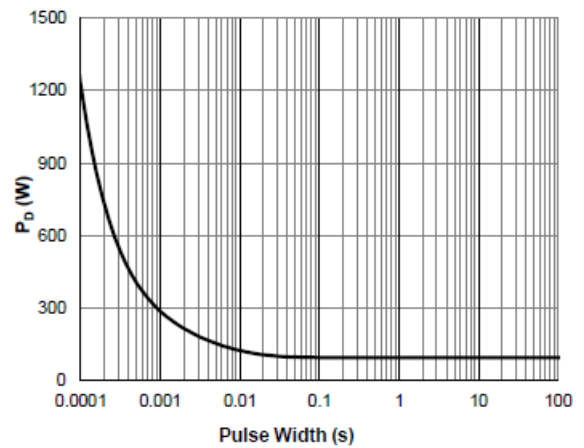

Figure 12. Single Pulse Power Rating, Junction to Case

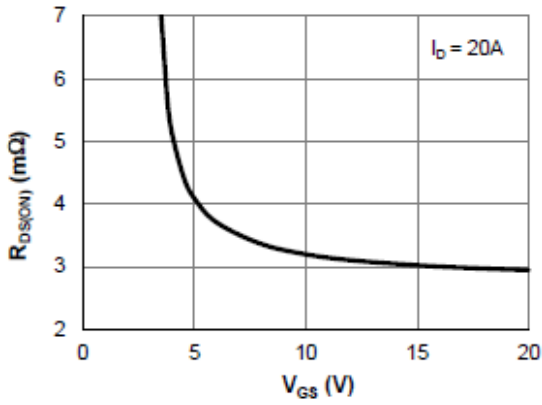

Figure 13. $R_{DS(ON)}$ vs. V_{GS}

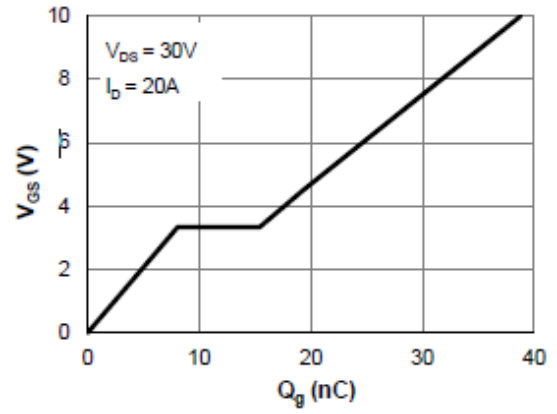

Figure 14. Gate Charge Characteristics

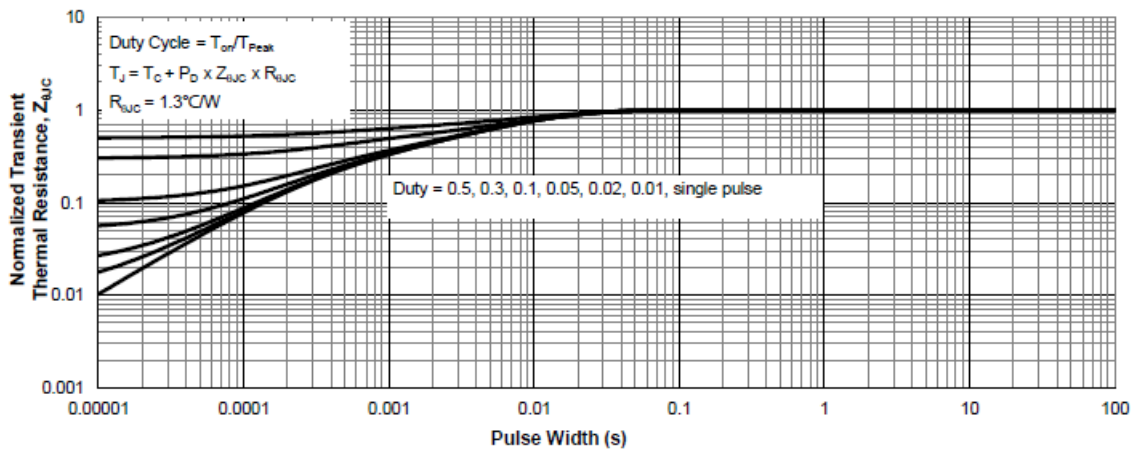
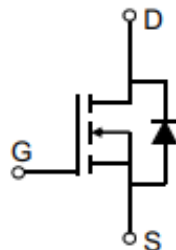
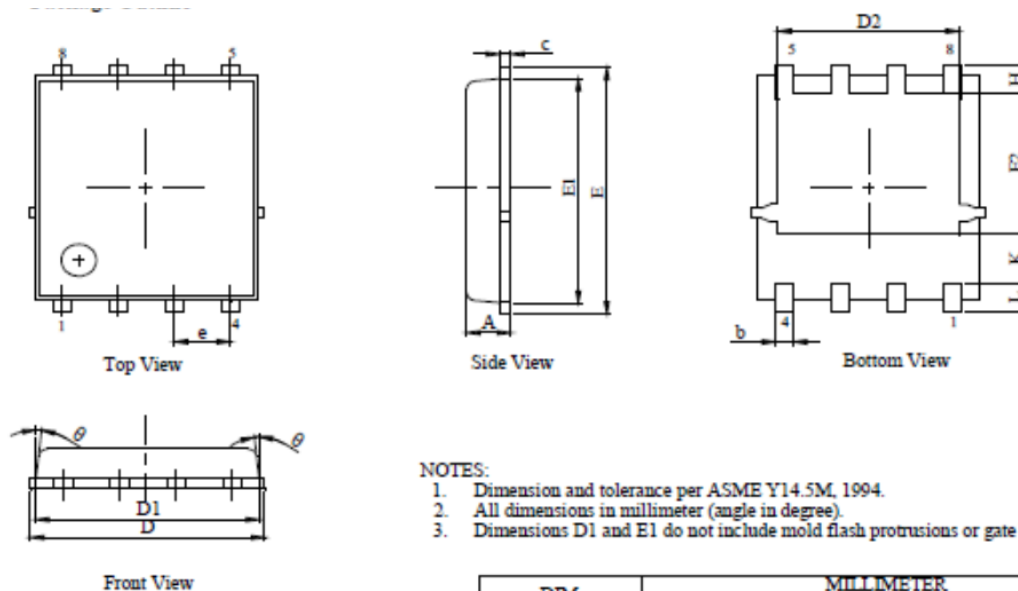

Figure 15. Normalized Maximum Transient Thermal Impedance

• Circuit diagram



• Package outlines :



- NOTES:
1. Dimension and tolerance per ASME Y14.5M, 1994.
 2. All dimensions in millimeter (angle in degree).
 3. Dimensions D1 and E1 do not include mold flash protrusions or gate burrs.

DIM	MILLIMETER		
	MIN.	NOM.	MAX.
A	0.90	1.00	1.10
b	0.31	0.41	0.51
c	0.20	0.25	0.30
D	5.00	5.20	5.40
D1	4.95	5.05	5.15
D2	4.00	4.10	4.20
E	6.05	6.15	6.25
E1	5.50	5.60	5.70
E2	3.42	3.53	3.63
e	1.27BSC		
H	0.60	0.70	0.80
L	0.50	0.70	0.80
θ	-	-	10°

Notice

MOSPEC reserves the rights to make changes of the content herein the document anytime without notification. MOSPEC or anyone on its behalf, assumes no responsibility or liability for any errors or inaccuracies. Please refer to MOSPEC website for the last document.

MOSPEC disclaims any and all liability arising out of the application or use of any product including damages incidentally and consequentially incurred.

Application shown on the herein document are examples of standard use and operation. Customers are responsible for comprehending suitable use in particular applications. MOSPEC makes no representation or warranty that such application will be suitable for the specified use without further testing or modification.

The information contained herein is presented only as a guide for the applications of our products. No responsibility is assumed by MOSPEC for any infringements of patents or other rights of the third parties which may result from its use. No license is granted by implication or otherwise under any patent or patent rights of MOSPEC or others.

These MOSPEC products are intended for usage in general electronic equipment. Please make sure to consult with MOSPEC before you use these MOSPEC products in equipment which require specialized quality and/or reliability, and in equipment which could have major impact to the welfare of human life (atomic energy control, aeronautics , traffic control, combustion control, safety devices etc.)