

## 60V N-Channel Power MOSFET

### DESCRIPTION :

- Excellent  $R_{DS(ON)}$
- Low Gate Charge
- Halogen-free
- Pb-Free Lead Plating
- RoHS compliant
- ESD Protected: 2K
- AEC-Q101 Qualified

$V_{DSS}$	60V
$I_D$	0.8A
$R_{DS(ON)_MAX}$ @ $V_{GS}=10V$	577m $\Omega$

### TYPICAL APPLICATIONS :

- Load Switch
- PWM Application
- General Automotive Application

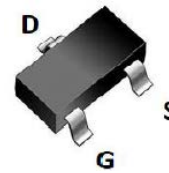

SOT-23

### MAXIMUM RATINGS (at $T_C = 25\text{ }^\circ\text{C}$ , unless otherwise specified)

Characteristic	Condition	Symbol	Value	Unit
Drain-Source Voltage		$V_{DSS}$	60	V
Gate-Source Voltage		$V_{GSS}$	$\pm 20$	V
Continuous Drain Current	$T_A=25^\circ\text{C}$ $T_A=100^\circ\text{C}$	$I_D$	0.8 0.5	A
Pulsed Drain Current		$I_{DM}$	Refer to Fig.4	A
Power dissipation	$T_A=25^\circ\text{C}$ $T_A=100^\circ\text{C}$	$P_D$	1.0 0.5	W
Junction & Storage temperature Range		$T_J, T_{STG}$	-55~+150	$^\circ\text{C}$

### THERMAL CHARACTERISTICS

Characteristic	Condition	Symbol	Value	Unit
Thermal resistance,	Junction to Ambient	$R_{\theta JA}^{\textcircled{1}}$	211	$^\circ\text{C}/\text{W}$
		$R_{\theta JA}^{\textcircled{2}}$	153	

#### Notes:

- ①.  $R_{\theta JA}$  is measured with the device mounted on a minimum recommended pad of 2oz copper FR4 PCB.
- ②.  $R_{\theta JA}$  is measured with the device mounted on a 1inch<sup>2</sup> pad of 2oz copper FR4 PCB.

**ELECTRICAL CHARACTERISTICS (at  $T_J = 25\text{ }^\circ\text{C}$ , unless otherwise specified)**

Characteristic	Symbol	Min.	Typ.	Max.	Unit
Drain-Source Breakdown Voltage VGS = 0V, ID = 250uA	$V_{(BR)DSS}$	60			V
Zero Gate Voltage Drain Current VDS = 60 V, VGS = 0 V	$I_{DSS}$			1.0	uA
Gate-Source Leakage Current VGS = $\pm 20$ V, VDS = 0V	$I_{GSS}$			$\pm 10$	uA
Gate-Source threshold voltage VDS = VGS, ID = 250uA	$V_{GS(th)}$	1.1	1.5	2.0	V
Drain-Source On-State Resistance VGS = 10V, ID = 0.3A VGS = 4.5V, ID = 0.2A	$R_{DS(on)}$		577 650	750 845	m $\Omega$
Gate Resistance f=1MHZ	$R_g$		15		$\Omega$
Input capacitance f=1MHz, VDS=30 V, VGS=0 V	$C_{iss}$		55		pF
Output capacitance f=1MHz, VDS=30 V, VGS=0 V	$C_{oss}$		12.2		pF
Reverse transfer capacitance f=1MHz, VDS=30 V, VGS=0 V	$C_{rss}$		6.8		pF
Total Gate Charge VDS= 30V, ID= 1A, VGS=0 to 10V	$Q_G$		1.9		nC
Gate to Source Charge VDS= 30V, ID= 1A, VGS=0 to 10V	$Q_{GS}$		0.5		nC
Gate to Drain Charge VDS= 30V, ID= 1A, VGS=0 to 10V	$Q_{GD}$		0.3		nC
Turn-on delay time VDD=30 V, VGS= 10V, ID= 0.3A, $R_{GEN}=3\Omega$	$t_{d(ON)}$		1.1		ns
Rise time VDD=30 V, VGS= 10V, ID= 0.3A, $R_{GEN}=3\Omega$	$t_r$		2.2		ns
Turn-off delay time VDD=30 V, VGS= 10V, ID= 0.3A, $R_{GEN}=3\Omega$	$t_{d(OFF)}$		6.7		ns
Fall time VDD=30 V, VGS= 10V, ID= 0.3A, $R_{GEN}=3\Omega$	$t_f$		8.9		ns

## Body Diode

ELECTRICAL CHARACTERISTICS (at  $T_J = 25\text{ }^\circ\text{C}$ , unless otherwise specified)

Characteristic	Symbol	Min.	Typ.	Max.	Unit
Diode Forward Voltage $V_{GS} = 0V, I_S = 0.3A$	$V_{SD}$			1.2	V
Maximum Continuous Body Diode Forward Current	$I_S$			0.8	A
Maximum Pulsed Body Diode Forward Current	$I_{SM}$			3.0	A
Diode Reverse Recovery Time $I_F = 1A, di/dt = 100A/\mu s$	trr		16		ns
Diode Reverse Recovery Charge $I_F = 1A, di/dt = 100A/\mu s$	Qrr		7.3		nC

Typical Performance Characteristics

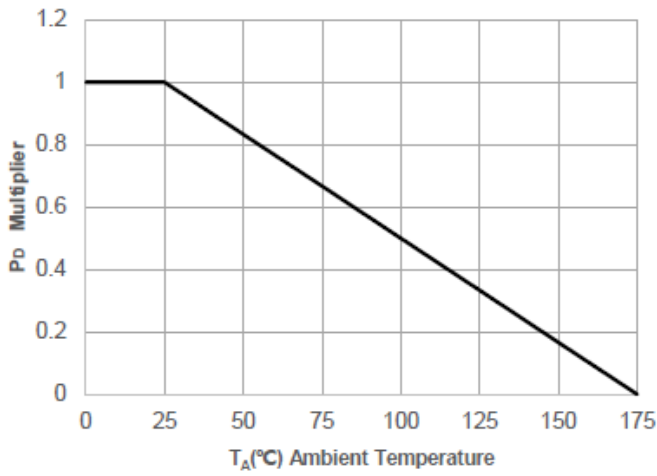

Figure 1. Power De-rating

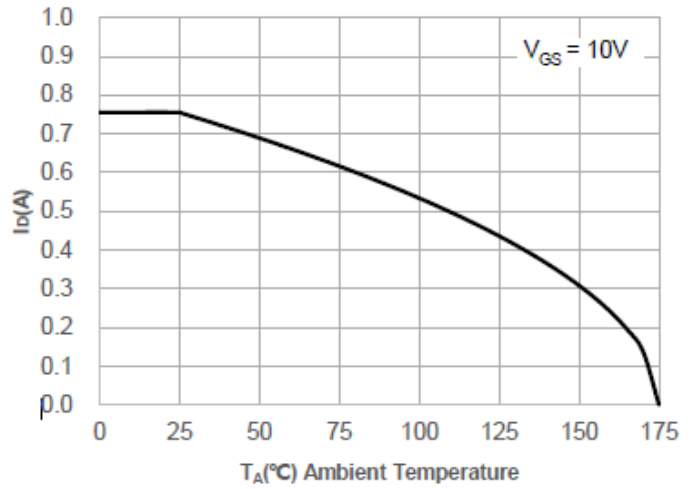

Figure 2. current De-rating

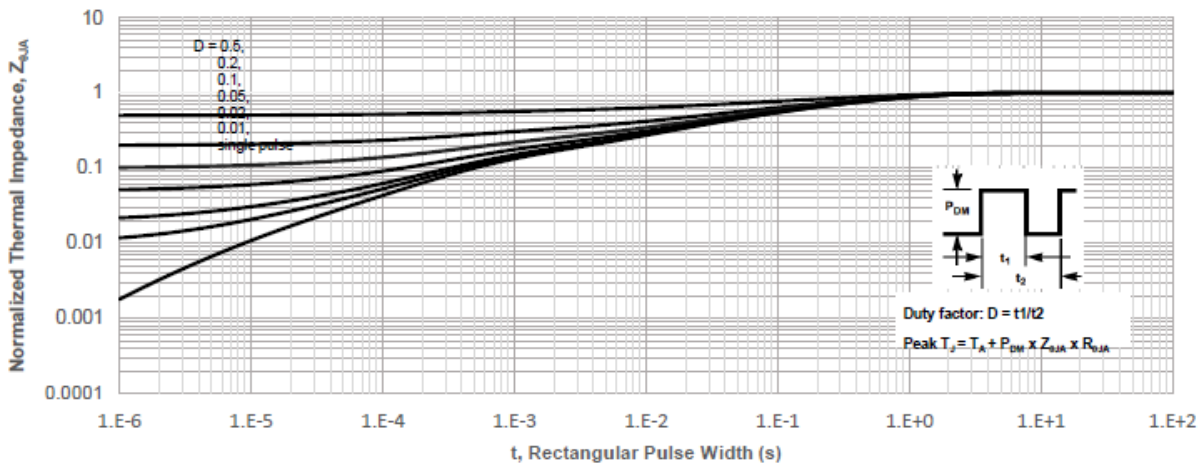

Figure 3. Normalized Maximum Transient Thermal Impedance

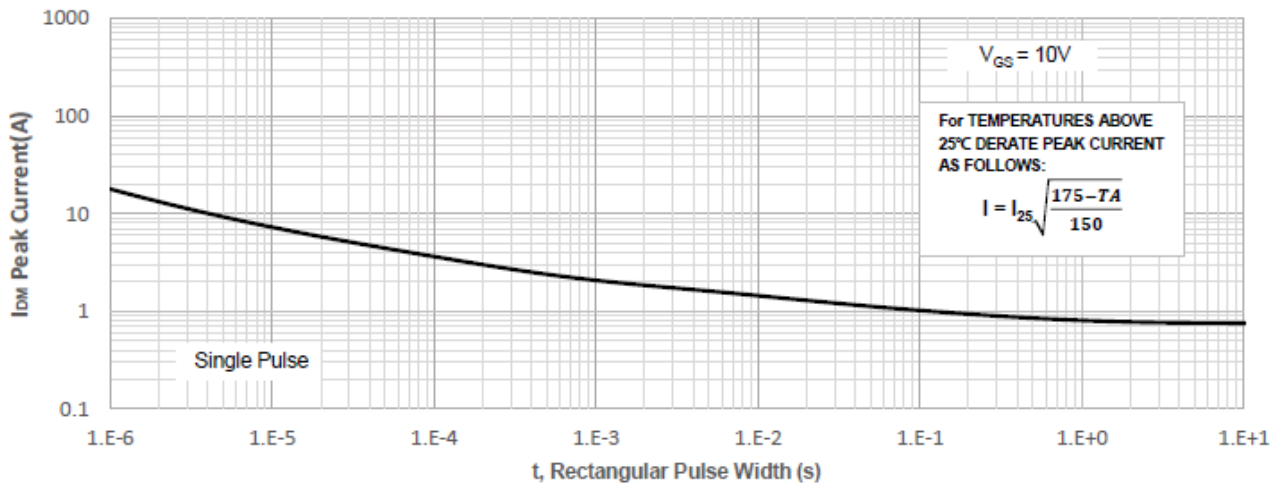

Figure 4: Peak current Capacity

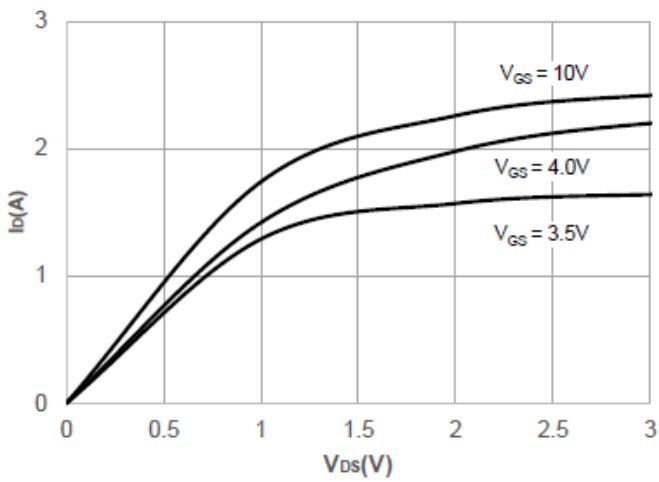

Figure 5: Output Characteristics

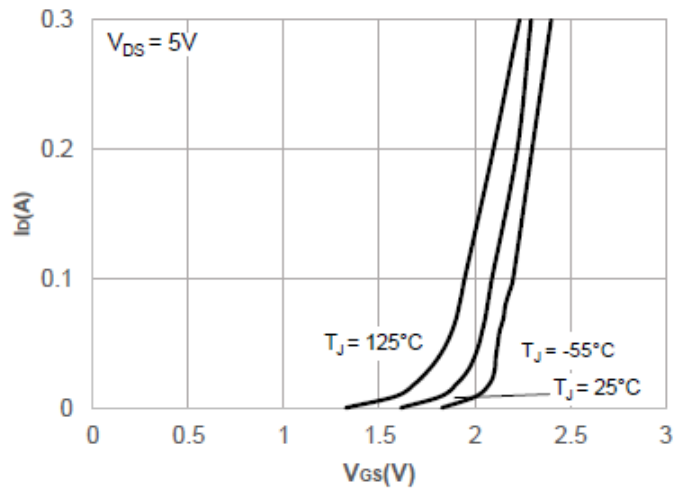

Figure 6: Typical Transfer Characteristics

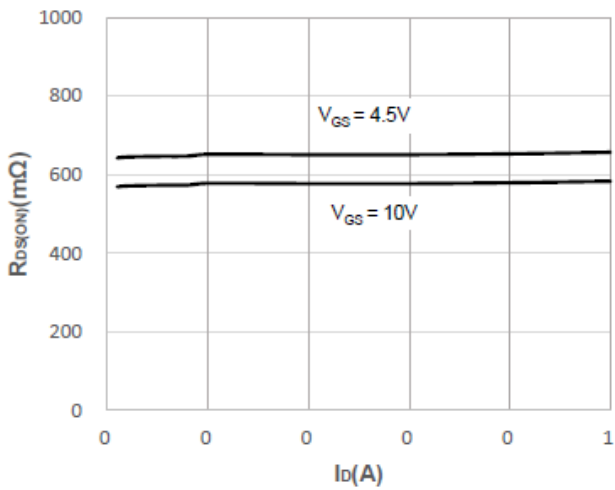

Figure 7: On-resistance vs. Drain Current

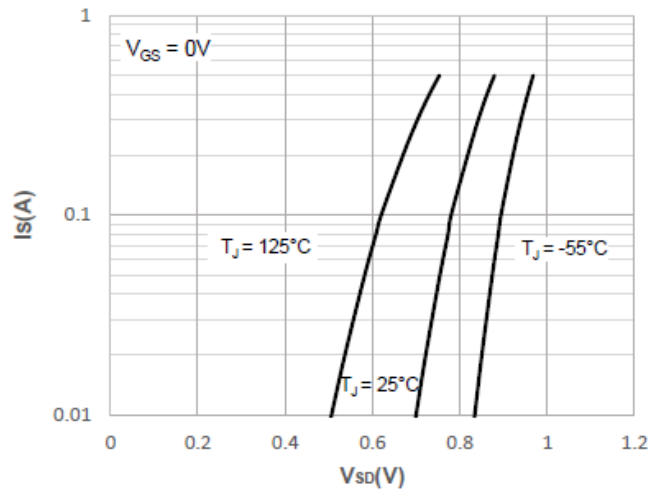

Figure 8: Body Diode Characteristics

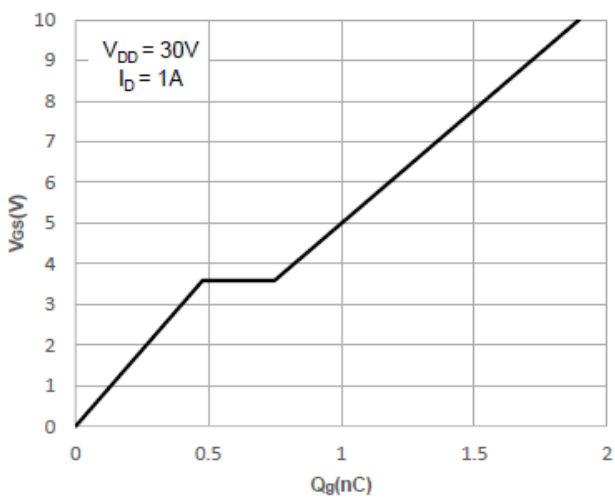

Figure 9: Gate Charge Characteristics

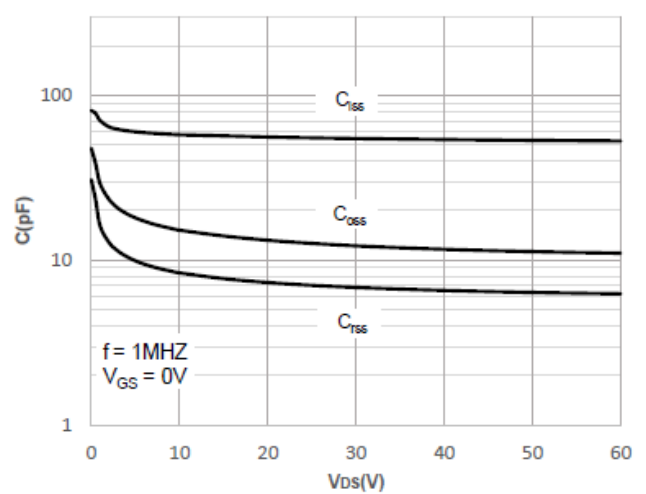

Figure 10: Capacitance Characteristics

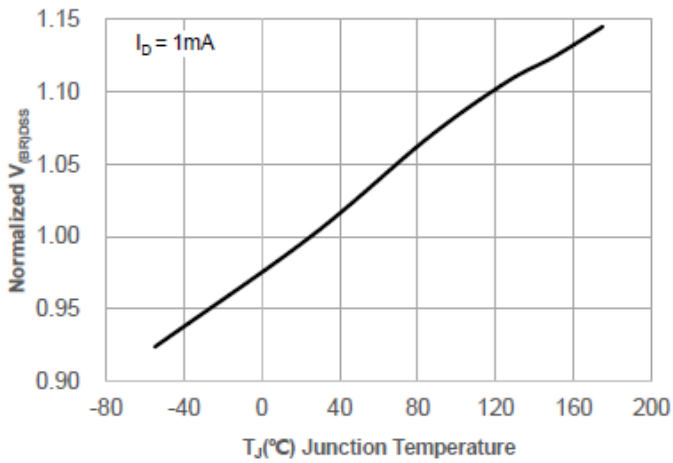

Figure 11: Normalized Breakdown voltage vs. Junction Temperature

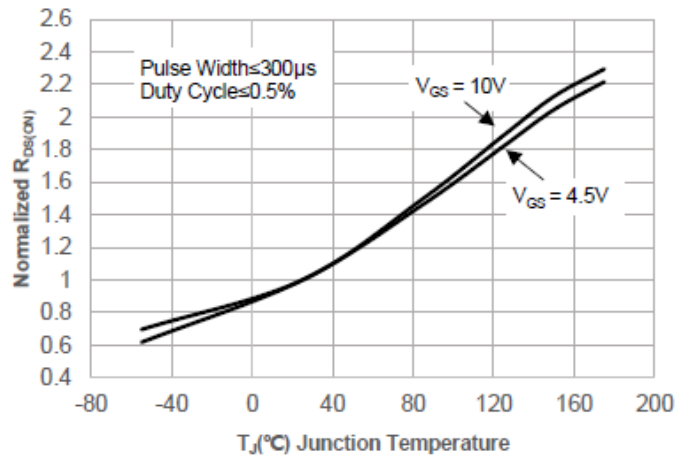

Figure 12: Normalized on Resistance vs. Junction Temperature

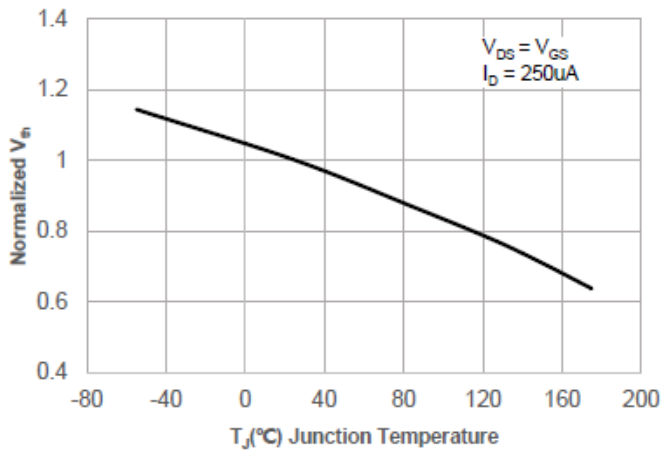

Figure 13: Normalized Threshold Voltage vs. Junction Temperature

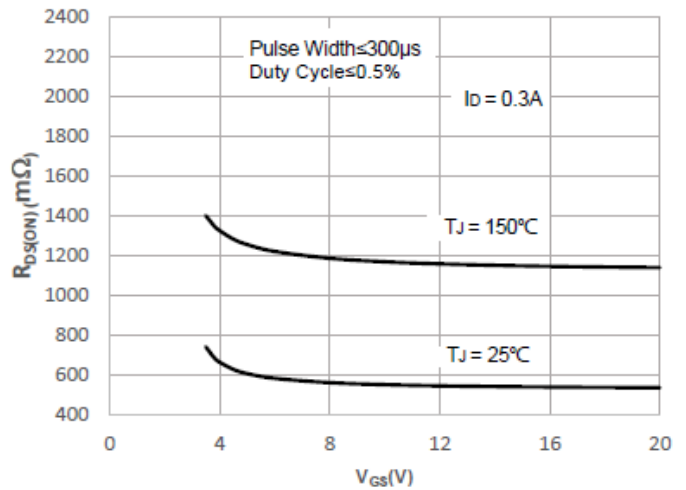

Figure 14:  $R_{DS(ON)}$  vs.  $V_{GS}$

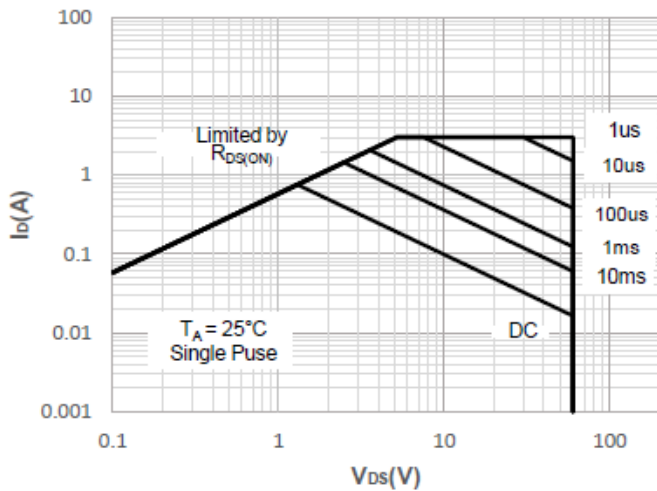
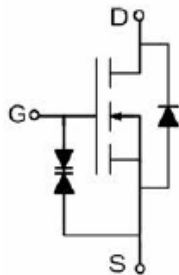
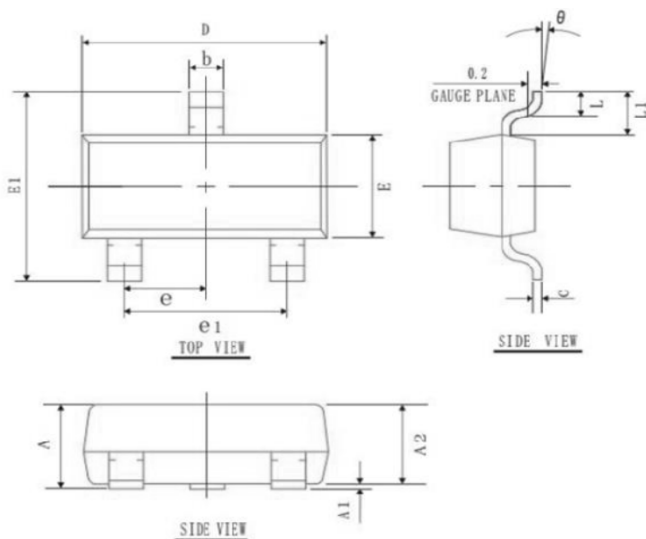

Figure 15: Maximum Safe Operating Area

- Circuit diagram



- Package outlines :



COMMON DIMENSIONS  
(UNITS OF MEASURE=mm)

SYMBOL	MIN	NOM	MAX
A	0.90	1.05	1.20
A1	0.00	0.05	0.10
A2	0.90	1.00	1.10
b	0.30	0.40	0.50
c	0.08	0.10	0.15
D	2.80	2.90	3.00
E	1.20	1.30	1.40
E1	2.30	2.40	2.50
L	0.30	0.40	0.50
$\theta$	0°	5°	10°
L1	0.55 REF		
e	0.95 BSC		
e1	1.90 REF		

## Notice

MOSPEC reserves the rights to make changes of the content herein the document anytime without notification. MOSPEC or anyone on its behalf, assumes no responsibility or liability for any errors or inaccuracies. Please refer to MOSPEC website for the last document.

MOSPEC disclaims any and all liability arising out of the application or use of any product including damages incidentally and consequentially incurred.

Application shown on the herein document are examples of standard use and operation. Customers are responsible for comprehending suitable use in particular applications. MOSPEC makes no representation or warranty that such application will be suitable for the specified use without further testing or modification.

The information contained herein is presented only as a guide for the applications of our products. No responsibility is assumed by MOSPEC for any infringements of patents or other rights of the third parties which may result from its use. No license is granted by implication or otherwise under any patent or patent rights of MOSPEC or others.

These MOSPEC products are intended for usage in general electronic equipment. Please make sure to consult with MOSPEC before you use these MOSPEC products in equipment which require specialized quality and/or reliability, and in equipment which could have major impact to the welfare of human life ( atomic energy control, aeronautics , traffic control, combustion control, safety devices etc.)