

## 60V N-Channel Power MOSFET

### DESCRIPTION :

- Load Switch for Portable Devices
- DC/DC Converter
- High density cell design for Low RDS(on)
- Voltage controlled small signal switch
- Rugged and reliable
- High saturation current capability
- ESD protected

$V_{(BR)DSS}$	60V
$I_D$	0.340A
$R_{DS(ON),MAX} @ V_{GS}=10V$	5Ω

### TYPICAL APPLICATIONS :

- SOT-323 Small Outline Plastic Package
- Epoxy UL: 94V-0.
- Mounting Position: Any.

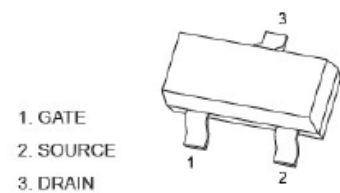

SOT-323

### MAXIMUM RATINGS (at $T_c = 25\text{ }^\circ\text{C}$ , unless otherwise specified)

Characteristic	Symbol	Value	Unit
Drain-Source Voltage	$V_{DS}$	60	V
Gate-Source Voltage	$V_{GS}$	±20	V
Continuous Drain Current	$I_D$	0.34	A
Pulsed Drain Current <sup>(1)</sup>	$I_{DM}$	0.80	A
Power dissipation	$P_D$	200	mW
Junction Temperature	$T_J$	150	°C
Storage Temperature	$T_{STG}$	-55~+150	°C
Thermal Resistance From Junction to Ambient	$R_{\theta JA}$	625	°C/W

Notes : 1. Repetitive Rating: Pulse Width Limited by Junction Temperature.

ELECTRICAL CHARACTERISTICS (at  $T_J = 25\text{ }^\circ\text{C}$ , unless otherwise specified)

Characteristic	Symbol	Min.	Typ.	Max.	Unit
Drain-Source Breakdown Voltage VGS = 0V, ID = 250uA	$V_{(BR)DSS}$	60			V
Gate-Source threshold voltage VDS = VGS, ID = 1mA	$V_{GS(th)}$	1.0	1.3	2.5	V
Gate-Source Leakage Current VGS = $\pm 20$ V, VDS = 0V	$I_{GSS}$			$\pm 10$	$\mu\text{A}$
Zero Gate Voltage Drain Current VDS=48 V, VGS=0V	$I_{DSS}$			1.0	$\mu\text{A}$
Drain-Source On-State Resistance VGS = 4.5V, ID = 200mA VGS = 10V, ID = 500mA	$R_{DS(on)}$		1.1 0.9	5.3 5	$\Omega$
Input capacitance f=1MHz, VDS=10 V, VGS=0 V	$C_{iss}$			40	pF
Output capacitance f=1MHz, VDS=10 V, VGS=0 V	$C_{oss}$			30	pF
Reverse transfer capacitance f=1MHz, VDS=10 V, VGS=0 V	$C_{rss}$			10	pF
Turn-on delay time VDD= 50V, VGS= 10V, RG=50 $\Omega$ , RL=250 $\Omega$ , RGS=50 $\Omega$	$t_{d(ON)}$			10	ns
Turn-off delay time VDD= 50V, VGS= 10V, RG=50 $\Omega$ , RL=250 $\Omega$ , RGS=50 $\Omega$	$t_{d(OFF)}$			15	ns
Reverse Recovery Time VGS=0V, IS=300mA, VR=25V, dIS/dt=-100A/us	$t_{rr}$		30		ns
Recovery Charge VGS=0V, IS=300mA, VR=25V, dIS/dt=-100A/us	$Q_r$		30		nC
Gate-Source Breakdown Voltage IGS= $\pm 1$ mA(Open Drain)	$BV_{GSO}$	$\pm 21.5$		$\pm 30$	V
Diode Forward Voltage IS=0.3A, VGS=0V	$V_{SD}$			1.5	V
Continuous Diode Forward Current	$I_S$			0.2	A
Pulsed Diode Forward Current	$I_{SM}$			0.53	A

Typical Performance Characteristics

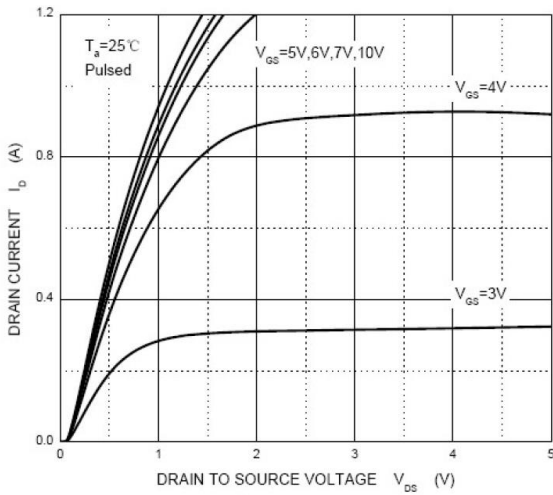

Figure 1. Output Characteristics

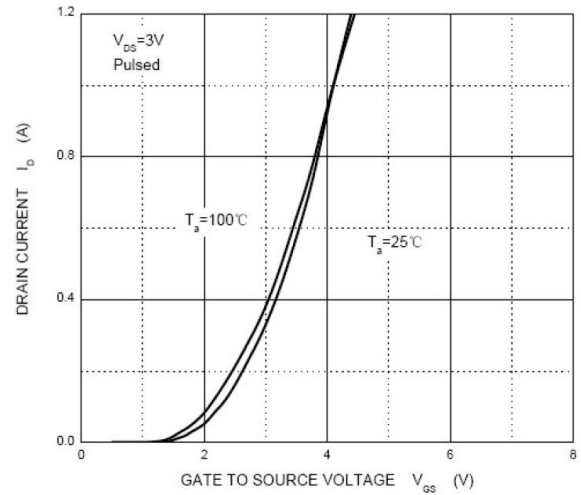

Figure 2. Transfer Characteristics

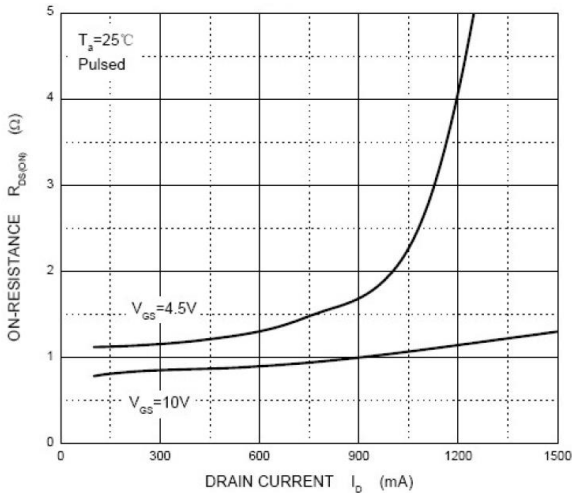

Figure 3.  $R_{DS(ON)}$  —  $I_D$

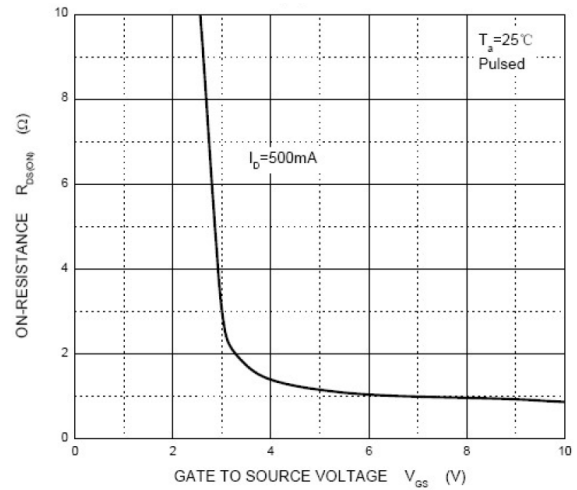

Figure 4.  $R_{DS(ON)}$  —  $V_{GS}$

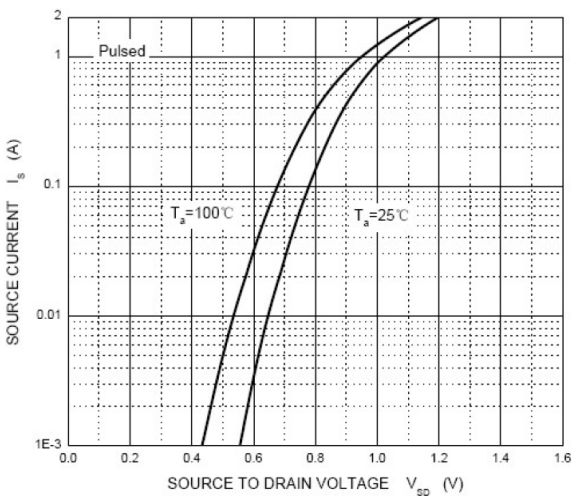

Figure 5.  $I_S$  —  $V_{SD}$

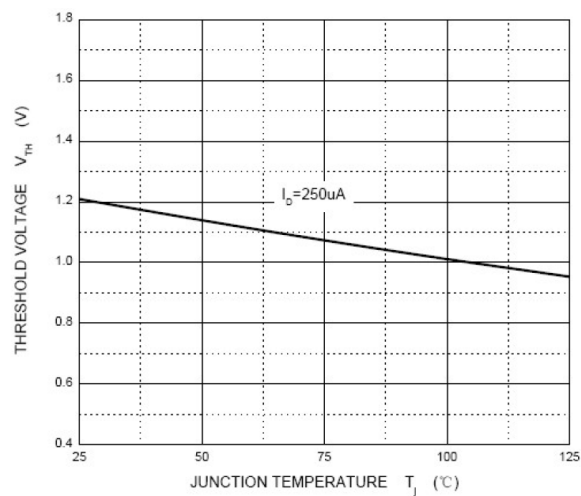
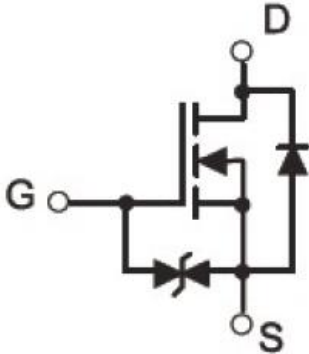
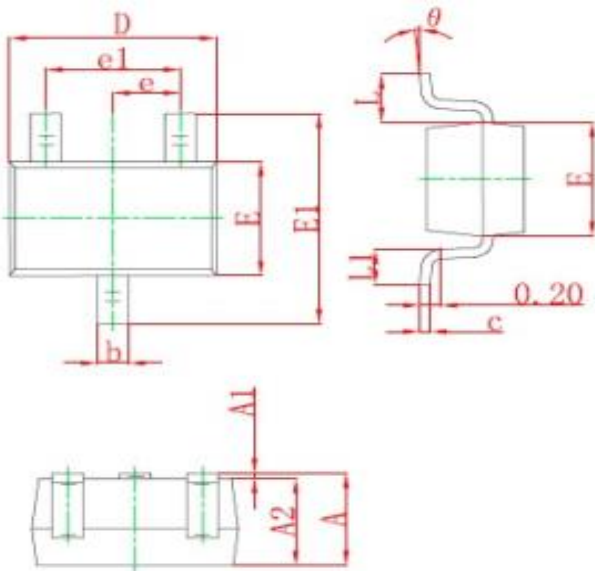

Figure 6. Threshold Voltage

·Circuit diagram



·Package outlines : Dimensions in (mm)



DIM	MILLIMETERS	
	MIN	MAX
A	0.90	1.10
A1	0.00	0.10
A2	0.90	1.00
b	0.20	0.40
c	0.08	0.15
D	2.00	2.20
E	1.15	1.35
E1	2.15	2.45
e	0.65 Typ.	
e1	1.20	1.40
L	0.525 Ref.	
L1	0.26	0.46
$\theta$	0°	8°

## Notice

MOSPEC reserves the rights to make changes of the content herein the document anytime without notification. MOSPEC or anyone on its behalf, assumes no responsibility or liability for any errors or inaccuracies. Please refer to MOSPEC website for the last document.

MOSPEC disclaims any and all liability arising out of the application or use of any product including damages incidentally and consequentially incurred.

Application shown on the herein document are examples of standard use and operation. Customers are responsible for comprehending suitable use in particular applications. MOSPEC makes no representation or warranty that such application will be suitable for the specified use without further testing or modification.

The information contained herein is presented only as a guide for the applications of our products. No responsibility is assumed by MOSPEC for any infringements of patents or other rights of the third parties which may result from its use. No license is granted by implication or otherwise under any patent or patent rights of MOSPEC or others.

These MOSPEC products are intended for usage in general electronic equipment. Please make sure to consult with MOSPEC before you use these MOSPEC products in equipment which require specialized quality and/or reliability, and in equipment which could have major impact to the welfare of human life ( atomic energy control, aeronautics , traffic control, combustion control, safety devices etc.)