

100V N-Channel Power MOSFET

DESCRIPTION :

- Advanced Trench Technology
- Low Gate Charge
- Excellent $R_{DS(ON)}$
- $R_{DS(ON)} < 125m\Omega @ V_{GS} = 10V$
- RoHS compliant

V_{DSS}	100V
I_D	3.0A
$R_{DS(ON)_MAX} @ V_{GS}=10V$	125m Ω

TYPICAL APPLICATIONS :

- Power Management
- Load Switch
- PWM Application



SOT-89

MAXIMUM RATINGS (at $T_A = 25^\circ C$, unless otherwise specified)

Characteristic	Condition	Symbol	Value	Unit
Drain-Source Voltage		V_{DS}	100	V
Gate-Source Voltage		V_{GS}	± 20	V
Continuous Drain Current	$T_A=25^\circ C$ $T_A=100^\circ C$	I_D	3 2	A
Pulsed Drain Current ⁽¹⁾		I_{DM}	12	A
Power dissipation		P_D	1.8	W
Junction & Storage temperature Range		T_J, T_{STG}	-55~+150	$^\circ C$

Notes : 1. Repetitive Rating: Pulse Width Limited by Maximum Junction Temperature.

THERMAL CHARACTERISTICS

Characteristic	Condition	Symbol	Value	Unit
Thermal resistance,	Junction to Ambient	$R_{\theta JA}$	69	$^\circ C/W$

ELECTRICAL CHARACTERISTICS (at $T_J = 25\text{ }^\circ\text{C}$, unless otherwise specified)

Characteristic	Symbol	Min.	Typ.	Max.	Unit
Drain-Source Breakdown Voltage VGS = 0V, ID = 250uA	$V_{(BR)DSS}$	100			V
Zero Gate Voltage Drain Current VDS = 100 V, VGS = 0 V	I_{DSS}			1	uA
Gate-Source Leakage Current VGS = ± 20 V, VDS = 0V	I_{GSS}			± 100	nA
Gate-Source threshold voltage VDS = VGS, ID = 250uA	$V_{GS(th)}$	1.0	1.5	2.5	V
Drain-Source On-State Resistance VGS = 10V, ID = 3A VGS = 4.5V, ID = 2A	$R_{DS(on)}$		95 100	125 140	m Ω
Input capacitance f=1MHz, VDS=25 V, VGS=0 V	C_{iss}		765		pF
Output capacitance f=1MHz, VDS=25 V, VGS=0 V	C_{oss}		38		pF
Reverse transfer capacitance f=1MHz, VDS=25 V, VGS=0 V	C_{rss}		33		pF
Total Gate Charge VDS= 50V, ID= 2A, VGS=10V	Q_G		18		nC
Gate to Source Charge VDS= 50V, ID= 2A, VGS=10V	Q_{GS}		2.5		nC
Gate to Drain Charge VDS= 50V, ID= 2A, VGS=10V	Q_{GD}		4		nC
Turn-on delay time VDS=50 V, VGS= 10V, ID= 3A, $R_G=1.8\Omega$	$t_{d(ON)}$		7.5		ns
Rise time VDS=50 V, VGS= 10V, ID= 3A, $R_G=1.8\Omega$	tr		6		ns
Turn-off delay time VDS=50 V, VGS= 10V, ID= 3A, $R_G=1.8\Omega$	$t_{d(OFF)}$		21		ns
Fall time VDS=50 V, VGS= 10V, ID= 3A, $R_G=1.8\Omega$	tf		9		ns

Body Diode

ELECTRICAL CHARACTERISTICS (at $T_J = 25\text{ }^\circ\text{C}$, unless otherwise specified)

Characteristic	Symbol	Min.	Typ.	Max.	Unit
Diode Forward Voltage $V_{GS} = 0V, I_S = 3A$	V_{SD}			1.2	V
Maximum Continuous Drain to Source Diode Forward Current	I_S			3	A
Maximum Pulsed Drain to Source Diode Forward Current	I_{SM}			12	A
Revers Recovery Time $I_F = 3A, di/dt = 100A/\mu s$	T_{rr}		21		ns
Revers Recovery Charge $I_F = 3A, di/dt = 100A/\mu s$	Q_{rr}		22		nC

Typical Performance Characteristics

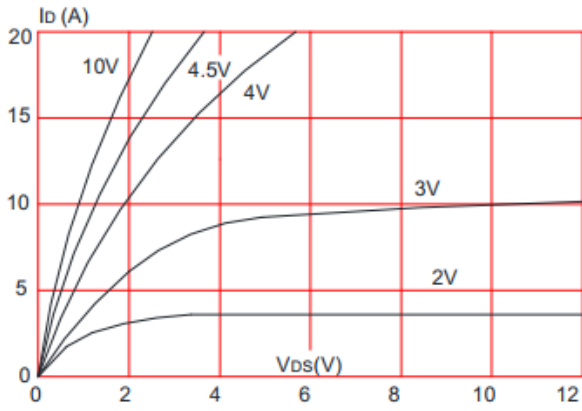

Figure 1. Output Characteristics

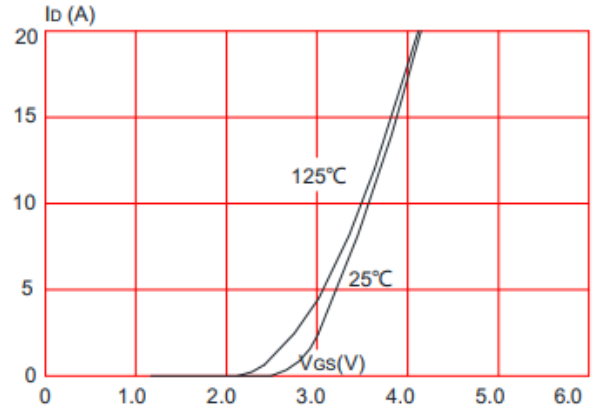

Figure 2. Typical Transfer Characteristics

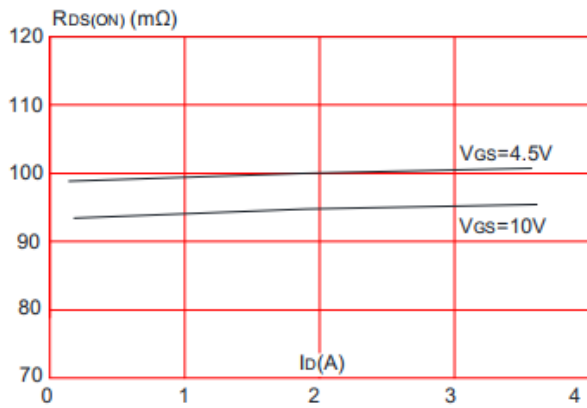

Figure 3. On-resistance vs. Drain Current

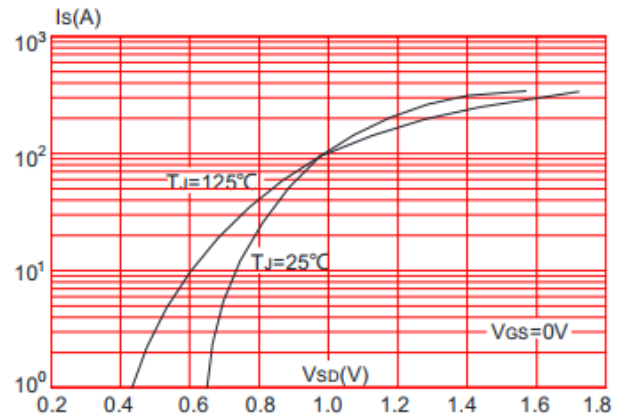

Figure 4. Body Diode Characteristics

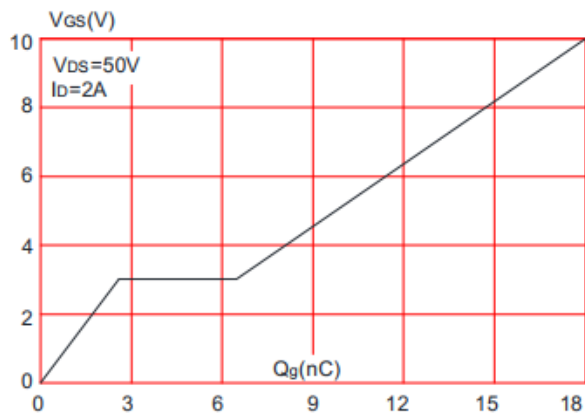

Figure 5. Gate Charge Characteristics

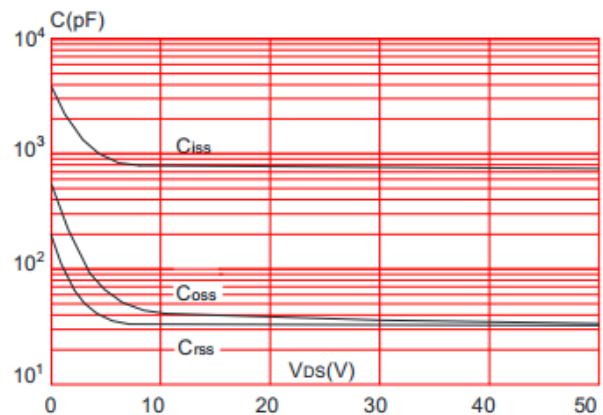

Figure 6. Capacitance Characteristics

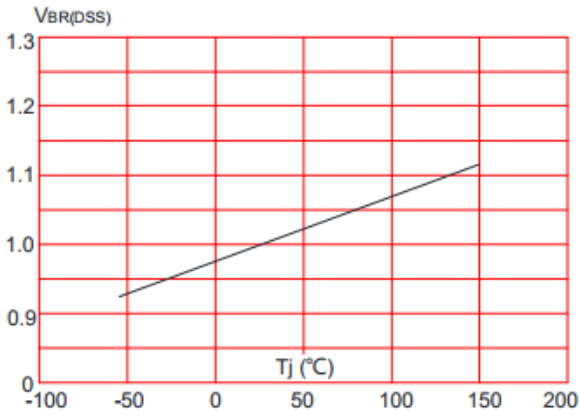

Figure 7. Normalized Breakdown Voltage vs. Junction Temperature

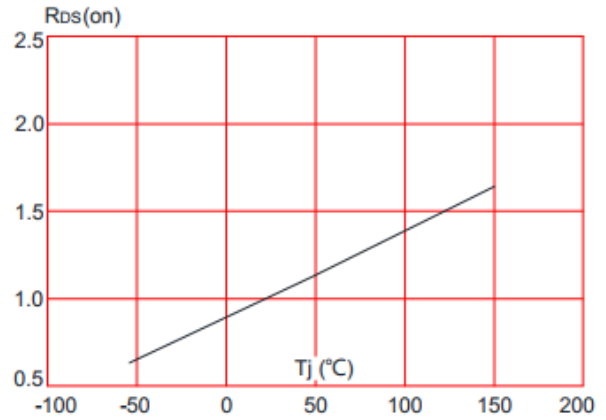

Figure 8. Normalized on Resistance vs. Junction Temperature

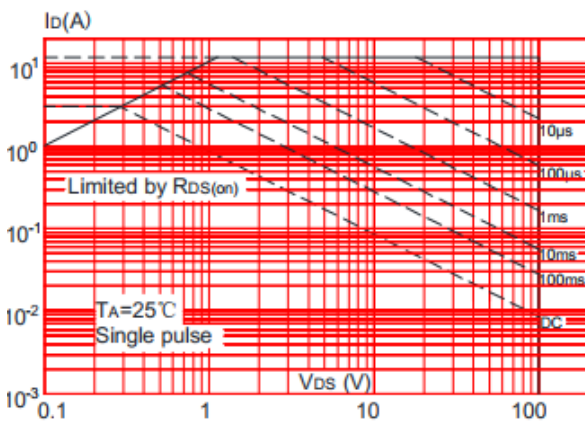

Figure 9. Maximum Safe Operating Area

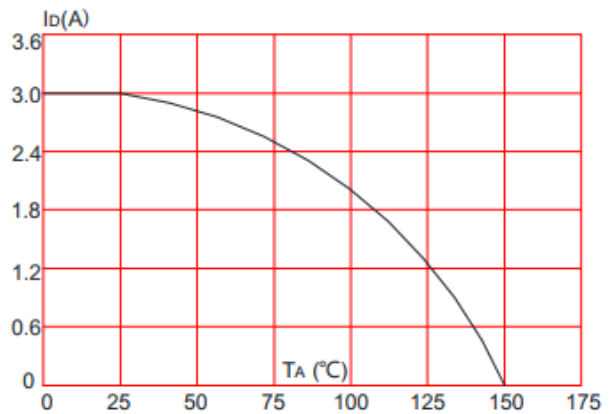

Figure 10. Maximum Continuous Drian Current vs. Ambient Temperature

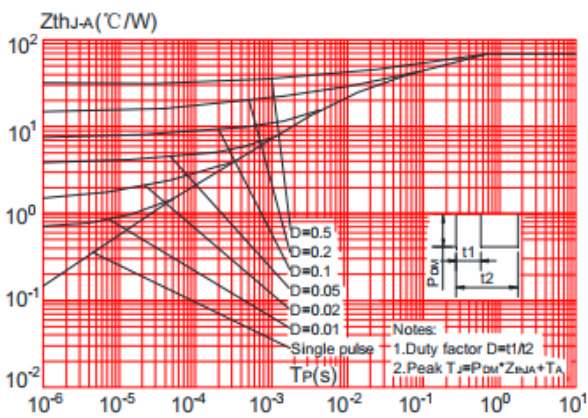
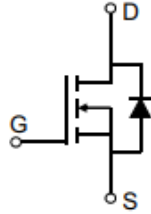
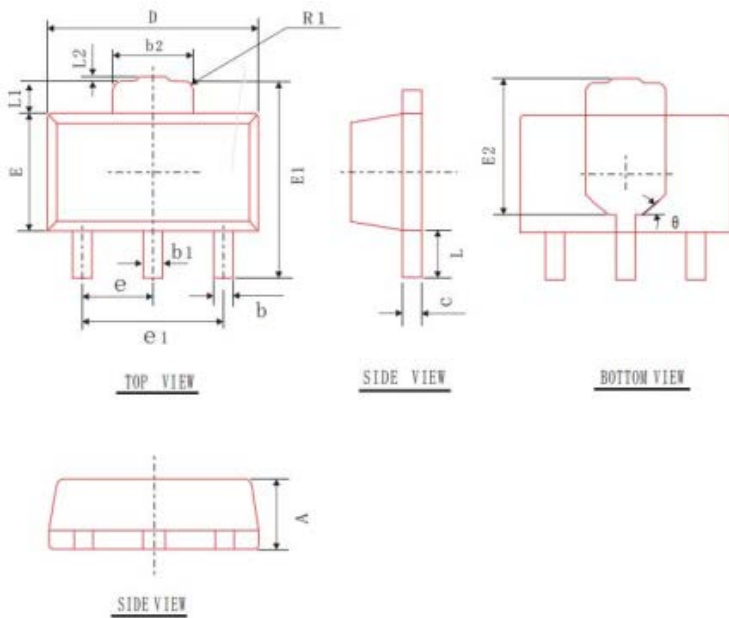

Figure 11. Maximum Effective Transient Thermal Impedance, Junction-to-Ambient

- Circuit diagram



- Package outlines : Dimensions in millimeters



SYMBOL	MIN	NOM	MAX
A	1.40	1.50	1.60
b	0.36	0.40	0.50
b 1	0.44	0.48	0.58
b 2	1.60	1.70	1.80
c	0.35	0.40	0.45
D	4.40	4.50	4.60
E	2.40	2.50	2.60
E 1	4.00	4.20	4.40
E 2	2.65	2.85	3.05
e 1	2.80	3.00	3.20
L	0.90	1.00	1.10
L 1	0.60	0.70	0.80
L 2	0.075 REF		
R 1	0.2 BSC		
θ	45° TYP		
e	1.5 BSC		

Notice

MOSPEC reserves the rights to make changes of the content herein the document anytime without notification. MOSPEC or anyone on its behalf, assumes no responsibility or liability for any errors or inaccuracies. Please refer to MOSPEC website for the last document.

MOSPEC disclaims any and all liability arising out of the application or use of any product including damages incidentally and consequentially incurred.

Application shown on the herein document are examples of standard use and operation. Customers are responsible for comprehending suitable use in particular applications. MOSPEC makes no representation or warranty that such application will be suitable for the specified use without further testing or modification.

The information contained herein is presented only as a guide for the applications of our products. No responsibility is assumed by MOSPEC for any infringements of patents or other rights of the third parties which may result from its use. No license is granted by implication or otherwise under any patent or patent rights of MOSPEC or others.

These MOSPEC products are intended for usage in general electronic equipment. Please make sure to consult with MOSPEC before you use these MOSPEC products in equipment which require specialized quality and/or reliability, and in equipment which could have major impact to the welfare of human life (atomic energy control, aeronautics , traffic control, combustion control, safety devices etc.)