

25Amp Bridge Rectifiers

FEATURES :

- Glass passivated chip
- Low forward voltage drop
- High surge current capability
- Compliant to RoHS directive 2011/65/EU

V _{RRM}	800-1600V
I _{F(AV)}	25A
I _{FSM}	400A

Applications :

- Industrial power supply
- Industrial automation equipment
- Electric welding machine



MECHANICAL DATA :

- Case : GBPC-W
- Polarity : Polarity symbols being marked on body



MAXIMUM RATINGS (Ratings at 25 °C ambient temperature unless otherwise specified)
Single phase half-wave 60Hz, resistive or inductive load, for capacitive load current derate by 20%.

Characteristic	Symbol	MT2508W	MT2510W	MT2512W	MT2514W	MT2516W	Unit
Maximum repetitive peak reverse voltage	V _{RRM}	800	1000	1200	1400	1600	V
Peak Forward Voltage I _F =12.5A	V _F	1.1				1.2	V
Average rectified output current with heatsink, T _C =85°C	I _(AV)	25					A
Peak surge forward current, 8.3ms single half sine-wave superimposed on rated load	I _{FSM}	400					A
Rating for using, 1ms<t<8.3ms, T _j =25 °C, Rating of per diode	I ² t	508					A ² s
Dielectric strength, terminals to case AC 1 minute	V _{dis}	2.5					KV
Peak Reverse Current V _R =V _{RRM} , Pulse measurement Rating of per diode (T _j =25 °C / 125 °C)	I _R	5 / 500					uA

MT2508W thru MT2516W

Junction temperature	T_J	-55~+150	°C
Storage temperature	T_{STG}	-55~+150	°C
Typical thermal resistance	$R_{\theta JA}$ $R_{\theta JC}$	26 0.95	°C/W
Operating junction and storage temperature range	T_J, T_{STG}	-55~+150	°C

RATINGS AND CHARACTERISTICS CURVES

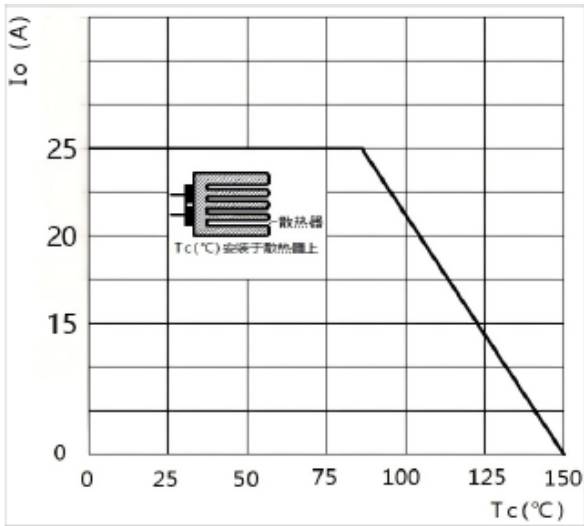

Figure 1. Derating Curve For Output Rectified Current

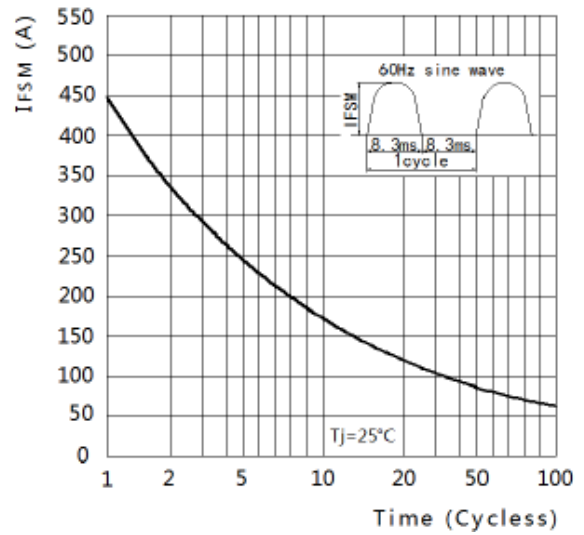

Figure 2. Maximum Non-Repetitive Peak Forward Surge Current Per Bridge Element

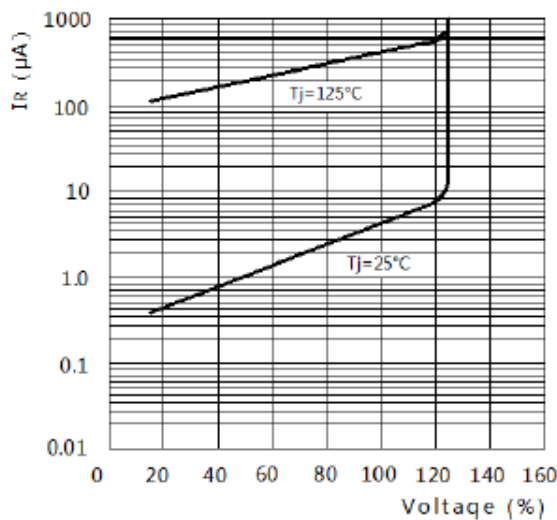

Figure 3. Typical Reverse Characteristics Per Bridge Element

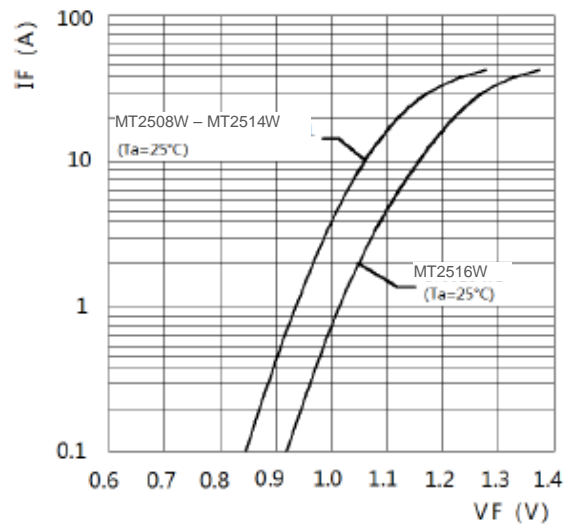
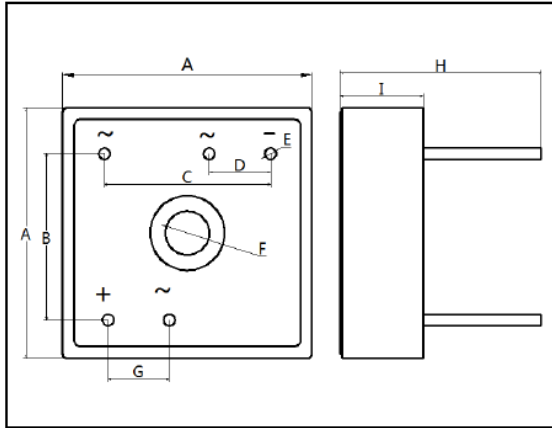

Figure 4. Typical Forward Characteristics Per Bridge Element

MT2508W thru MT2516W

- Package outlines : Dimensions in inches and (millimeters)



Dim.	Unit(mm)		Unit(inch)	
	Min.	Max.	Min.	Max.
A	28.00	29.00	1.102	1.142
B	18.50	19.50	0.728	0.768
C	18.50	19.50	0.728	0.768
D	6.50	7.50	0.256	0.295
E	1.10	1.50	0.043	0.059
F	4.50	5.50	0.177	0.217
G	6.50	7.50	0.256	0.295
H	22.00	24.00	0.866	0.945
I	9.00	10.00	0.354	0.394

Notice

MOSPEC reserves the rights to make changes of the content herein the document anytime without notification. MOSPEC or anyone on its behalf, assumes no responsibility or liability for any errors or inaccuracies. Please refer to MOSPEC website for the last document.

MOSPEC disclaims any and all liability arising out of the application or use of any product including damages incidentally and consequentially incurred.

Application shown on the herein document are examples of standard use and operation. Customers are responsible for comprehending suitable use in particular applications. MOSPEC makes no representation or warranty that such application will be suitable for the specified use without further testing or modification.

The information contained herein is presented only as a guide for the applications of our products. No responsibility is assumed by MOSPEC for any infringements of patents or other rights of the third parties which may result from its use. No license is granted by implication or otherwise under any patent or patent rights of MOSPEC or others.

These MOSPEC products are intended for usage in general electronic equipment. Please make sure to consult with MOSPEC before you use these MOSPEC products in equipment which require specialized quality and/or reliability, and in equipment which could have major impact to the welfare of human life (atomic energy control, aeronautics , traffic control, combustion control, safety devices etc.)