

### 6A Bridge Rectifiers

#### FEATURES :

- Reliable low cost construction utilizing molded plastic technique.
- Glass passivated chip junction.
- Ideal for printed circuit board.
- Low reverse leakage current.
- High surge current capability.
- RoHS compliant

#### MECHANICAL DATA :

- Case : Molded plastic, GBU
- Epoxy: UL 94V-O rate flame retardant
- Polarity: Marked on body
- Mounting position: Any



#### MAXIMUM RATINGS AND ELECTRICAL CHARACTERISTICS

(Rating at 25 C ambient temperature unless otherwise specified. Single, half wave, 60Hz resistive or inductive load. For capacitive load, derate current by 20%)

Characteristic	Symbol	GBU601	GBU602	GBU604	GBU606	GBU608	GBU610	Unit
Maximum Reverse Peak Reverse Voltage	$V_{RRM}$	100	200	400	600	800	1000	V
Maximum RMS Voltage	$V_{RMS}$	70	140	280	420	560	700	V
Maximum DC Blocking Voltage	$V_{DC}$	100	200	400	600	800	1000	V
Maximum Average Forward Rectified Current	$I_{F(AV)}$	6.0						A
Peak forward surge current, 8.3ms single half sine-wave superimposed on rated load	$I_{FSM}$	175						A
Rating for Fusing (t =8 3ms . )	$I^2t$	127						A <sup>2</sup> S
Forward Voltage $I_F=3A$	$V_F$	1.0						V
Maximum DC reverse current at rated DC blocking voltage ( $T_A=25^{\circ}C$ / $T_A=125^{\circ}C$ )	$I_R$	5 / 100						uA
Typical Junction Capacitance <sup>(1)</sup>	$C_J$	50						pF
Typical Thermal resistance, Junction to Ambient	$R_{\theta JA}$	25						°C/W

Typical Thermal resistance, Junction to Case	$R_{\theta JC}$	2.2	$^{\circ}C/W$
Operating temperature range	$T_J$	-55 ~ +150	$^{\circ}C$
Storage temperature range	$T_{STG}$	-55 ~ +150	$^{\circ}C$

Note : 1.Measured at 1MHz and applied reverse voltage of 4.0 Volts

RATINGS AND CHARACTERISTICS CURVES

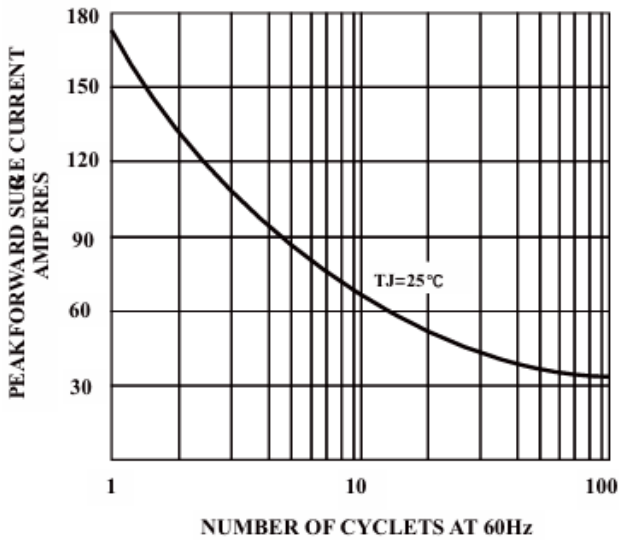

Figure 1. MAXIMUM FORWARD SURGE CURRENT

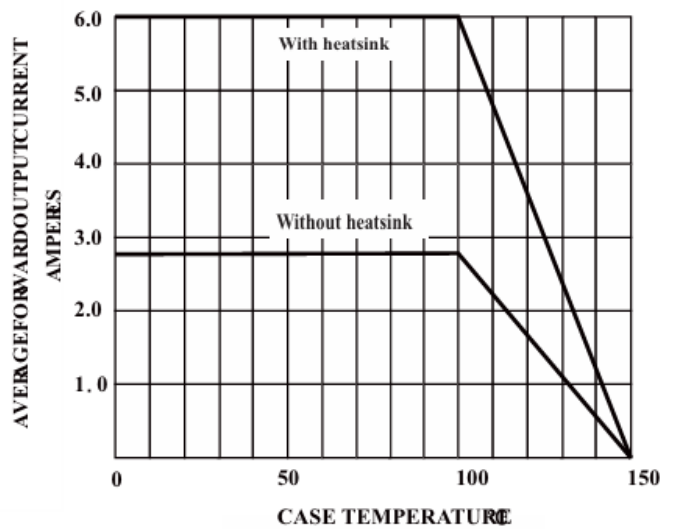

Figure 2. FORWARD CURRENT DERATING CURVE

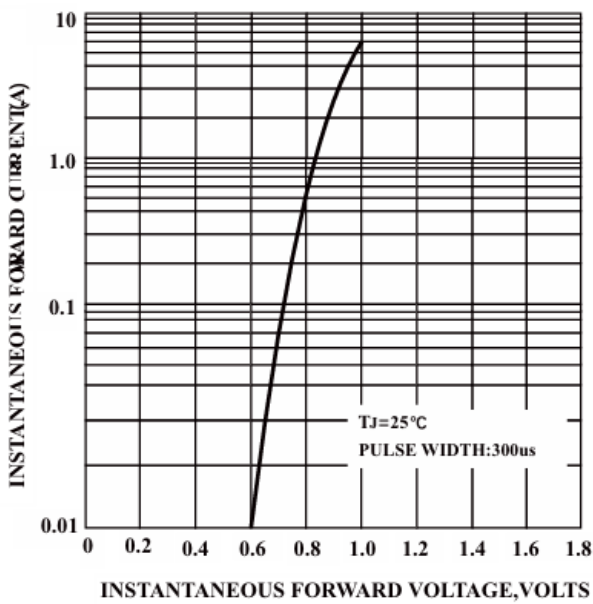

Figure 3. TYPICAL FORWARD CHARACTERISTICS

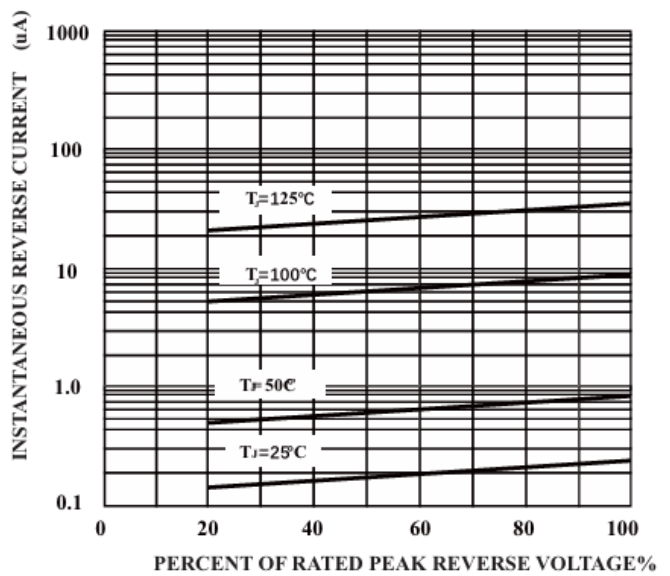
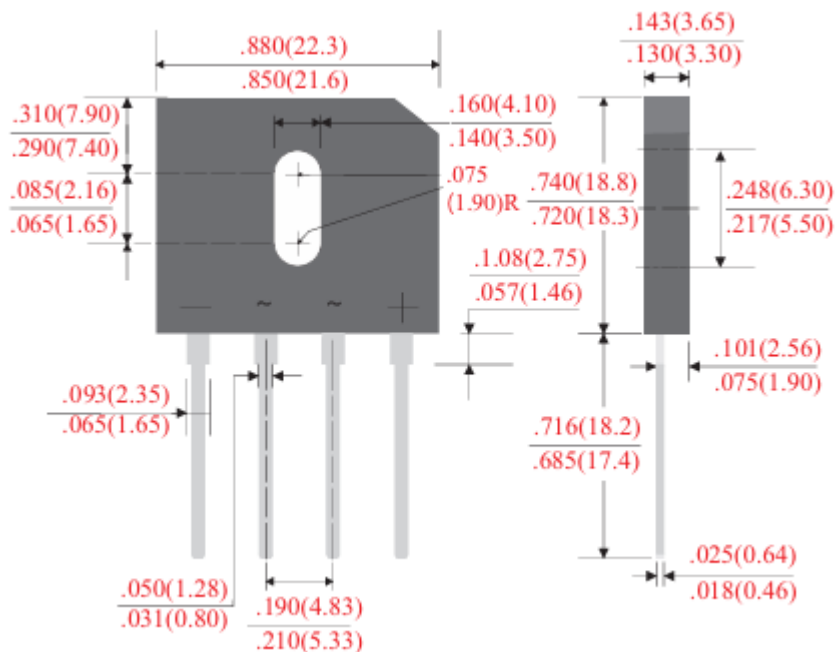

Figure 4. TYPICAL REVERSE LEAKAGE CHARACTERISTICS

- Package outlines : Dimensions in inches (millimeters)



## Notice

MOSPEC reserves the rights to make changes of the content herein the document anytime without notification. MOSPEC or anyone on its behalf, assumes no responsibility or liability for any errors or inaccuracies. Please refer to MOSPEC website for the last document.

MOSPEC disclaims any and all liability arising out of the application or use of any product including damages incidentally and consequentially incurred.

Application shown on the herein document are examples of standard use and operation. Customers are responsible for comprehending suitable use in particular applications. MOSPEC makes no representation or warranty that such application will be suitable for the specified use without further testing or modification.

The information contained herein is presented only as a guide for the applications of our products. No responsibility is assumed by MOSPEC for any infringements of patents or other rights of the third parties which may result from its use. No license is granted by implication or otherwise under any patent or patent rights of MOSPEC or others.

These MOSPEC products are intended for usage in general electronic equipment. Please make sure to consult with MOSPEC before you use these MOSPEC products in equipment which require specialized quality and/or reliability, and in equipment which could have major impact to the welfare of human life ( atomic energy control, aeronautics , traffic control, combustion control, safety devices etc.)