

15.0Amp Glass passivated Bridge Rectifiers
FEATURES :

- The plastic package carries Underwriters Laboratory Flammability Classification 94V-0
- High current capability
- Glass passivated junction chip
- Low forward voltage drop.
- High temperature soldering guaranteed
260 C/10 seconds at terminals
- RoHS compliant.

MECHANICAL DATA :

Case : Molded plastic body, GBJ
 Terminals : Solder plated, solderable per MIL-STD-750,
 Method 2026
 Polarity : As Marked on Body
 Mounting Position : Any

MAXIMUM RATINGS (Ratings at 25 °C ambient temperature unless otherwise specified)
 Single phase half-wave 60Hz, resistive or inductive load, for capacitive load current derate by 20%.

| Characteristic | Symbol | GBJ 1501 | GBJ 1502 | GBJ 1504 | GBJ 1506 | GBJ 1508 | GBJ 1510 | Unit |
|--|-------------|----------|----------|----------|----------|----------|----------|------------------|
| Maximum repetitive peak reverse voltage | V_{RRM} | 100 | 200 | 400 | 600 | 800 | 1000 | V |
| Maximum RMS voltage | V_{RMS} | 70 | 140 | 280 | 420 | 560 | 700 | V |
| Maximum DC blocking voltage | V_{DC} | 100 | 200 | 400 | 600 | 800 | 1000 | V |
| Maximum average forward rectified current | $I_{F(AV)}$ | 15 | | | | | | A |
| Peak forward surge current, 8.3ms single half sine-wave superimposed on rated load | I_{FSM} | 220 | | | | | | A |
| Rating for fusing (t=8.3ms, Ta=25 °C) | I^2t | 200 | | | | | | A ² s |
| Maximum instantaneous forward voltage at 7.5A | V_F | 1.10 | | | | | | V |
| Maximum DC reverse current at rated DC blocking voltage (T _J =25 °C / 125 °C) | I_R | 5 / 100 | | | | | | uA |

| | | | |
|--|------------------------------------|-----------|------|
| Typical thermal resistance | $R_{\theta JA}$ $R_{\theta JC}$ | 18 1.5 | °C/W |
| Operating junction and storage temperature range | T_J, T_{STG} | -55~+150 | °C |

RATINGS AND CHARACTERISTICS CURVES

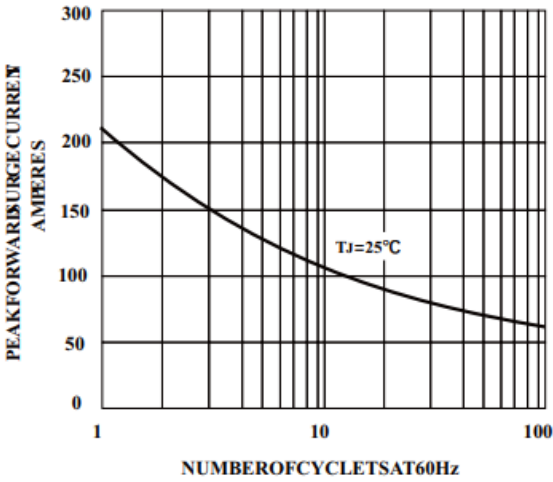

Figure 1. MAXIMUM FORWARD SURGE CURRENT

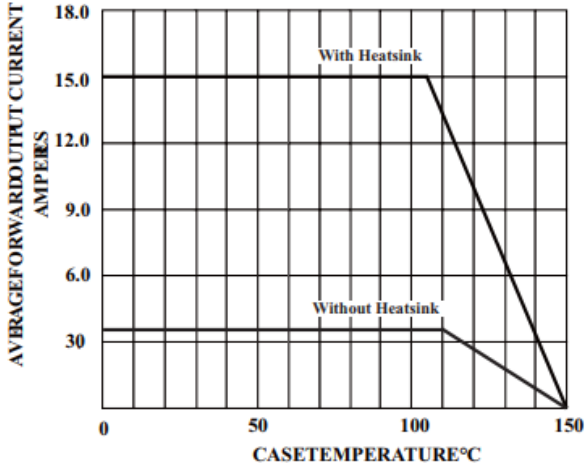

Figure 2. FORWARD CURRENT DERATING CURVE

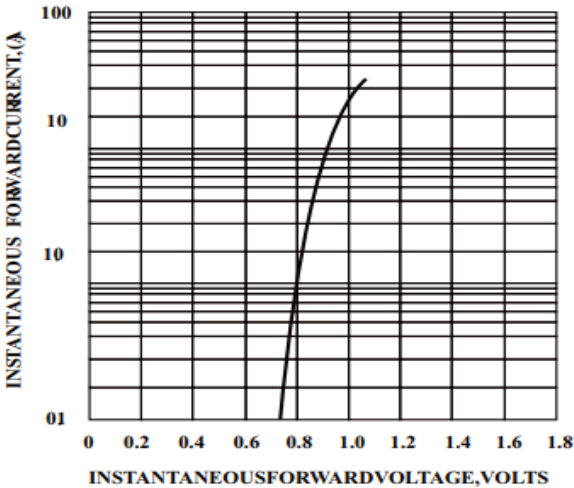

Figure 3. TYPICAL FORWARD CHARACTERISTICS

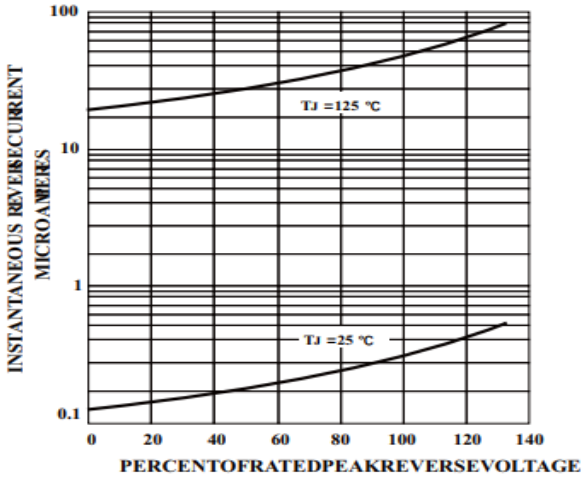
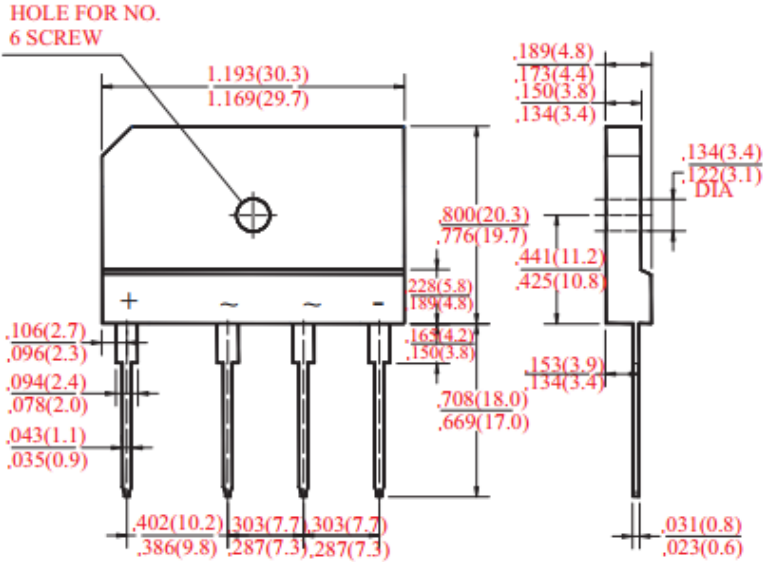
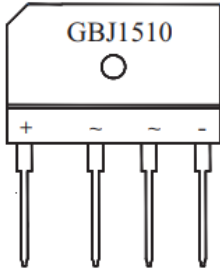

Figure 4. TYPICAL REVERSE CHARACTERISTICS

• Package outlines : Dimensions in inches and (millimeters)



• Marking :



| Part No | Marking code |
|---------|--------------|
| GBJ1501 | GBJ1501 |
| GBJ1502 | GBJ1502 |
| GBJ1504 | GBJ1504 |
| GBJ1506 | GBJ1506 |
| GBJ1508 | GBJ1508 |
| GBJ1510 | GBJ1510 |

Notice

MOSPEC reserves the rights to make changes of the content herein the document anytime without notification. MOSPEC or anyone on its behalf, assumes no responsibility or liability for any errors or inaccuracies. Please refer to MOSPEC website for the last document.

MOSPEC disclaims any and all liability arising out of the application or use of any product including damages incidentally and consequentially incurred.

Application shown on the herein document are examples of standard use and operation. Customers are responsible for comprehending suitable use in particular applications. MOSPEC makes no representation or warranty that such application will be suitable for the specified use without further testing or modification.

The information contained herein is presented only as a guide for the applications of our products. No responsibility is assumed by MOSPEC for any infringements of patents or other rights of the third parties which may result from its use. No license is granted by implication or otherwise under any patent or patent rights of MOSPEC or others.

These MOSPEC products are intended for usage in general electronic equipment. Please make sure to consult with MOSPEC before you use these MOSPEC products in equipment which require specialized quality and/or reliability, and in equipment which could have major impact to the welfare of human life (atomic energy control, aeronautics , traffic control, combustion control, safety devices etc.)