

### Silicon PNP Power Transistors

#### DESCRIPTION

- Low Collector Saturation Voltage-  
:  $V_{CE(sat)} = 2.0V(\text{Min}) @ I_C = 7A$
- Good Linearity of  $h_{FE}$
- Complement to Type 2SC5198

#### APPLICATIONS

- Power amplifier applications
- Recommend for 70W high fidelity audio frequency amplifier output stage applications

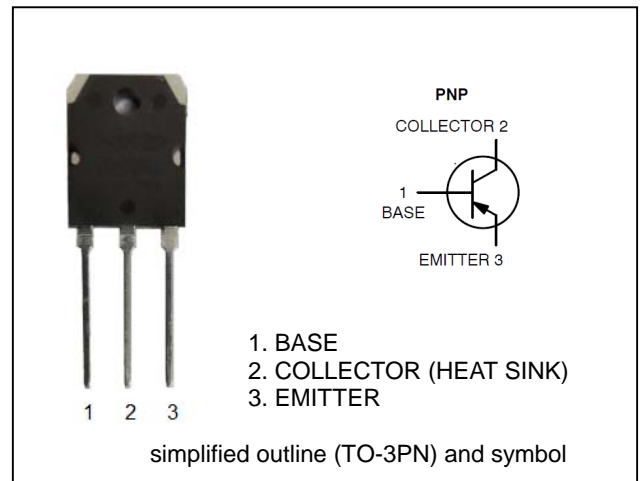

#### MAXIMUM RATINGS

Characteristic	Symbol	Min	Unit
Collector-Base Voltage	$V_{CBO}$	140	V
Collector-Emitter Voltage	$V_{CEO}$	140	V
Emitter-Base Voltage	$V_{EBO}$	5	V
Collector Current	$I_C$	10	A
Base current	$I_B$	1	A
Collector power dissipation @ $T_c=25^\circ\text{C}$	$P_C$	120	W
Junction Temperature	$T_j$	150	$^\circ\text{C}$
Storage Temperature Range	$T_{stg}$	-65 to +150	$^\circ\text{C}$

#### ELECTRICAL CHARACTERISTICS ( $T_c=25^\circ\text{C}$ unless otherwise notes)

Characteristic	Symbol	Min.	Typ.	Max.	Unit
Collector-Emitter Breakdown Voltage ( $I_C = 50 \text{ mA}, I_B = 0$ )	$V_{CEO}$	140			V
Collector Cutoff Current ( $V_{CB} = 140 \text{ V}, I_E = 0 \text{ V}$ )	$I_{CBO}$			5	$\mu\text{A}$
Emitter Cutoff Current ( $V_{EB} = 5.0 \text{ V}, I_C = 0$ )	$I_{EBO}$			5	$\mu\text{A}$
DC Current Gain ( $I_C = 1.0 \text{ A}, V_{CE} = 5.0 \text{ V}$ )	$h_{FE(1)}$ (Note)	55		160	
DC Current Gain ( $I_C = 5.0 \text{ A}, V_{CE} = 5.0 \text{ V}$ )	$h_{FE(2)}$	35			
Collector-Emitter Saturation Voltage ( $I_C = 7.0 \text{ A}, I_B = 0.7 \text{ A}$ )	$V_{CE(SAT)}$			2.0	V
Base-Emitter On Voltage ( $I_C = 5.0 \text{ A}, V_{CE} = 5.0 \text{ V}$ )	$V_{BE(ON)}$			1.5	V
Output Capacitance ( $I_E = 0, V_{CB} = 10 \text{ V}, f = 1.0 \text{ MHz}$ )	$C_{OB}$		170		pF
Current-Gain—Bandwidth Product ( $I_C = 1 \text{ A}; V_{CE} = 5 \text{ V}$ )	$f_T$		30		MHz

Note :  $h_{FE(1)}$  Classifications R : 55~110 , O :

FIG-1  $I_C$ - $V_{CE}$  CHARACTERISTICS

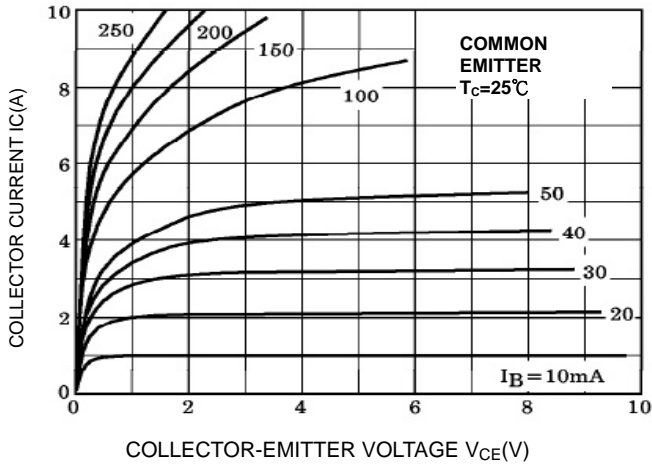

FIG-2  $I_C$ - $V_{BE}$  CHARACTERISTICS

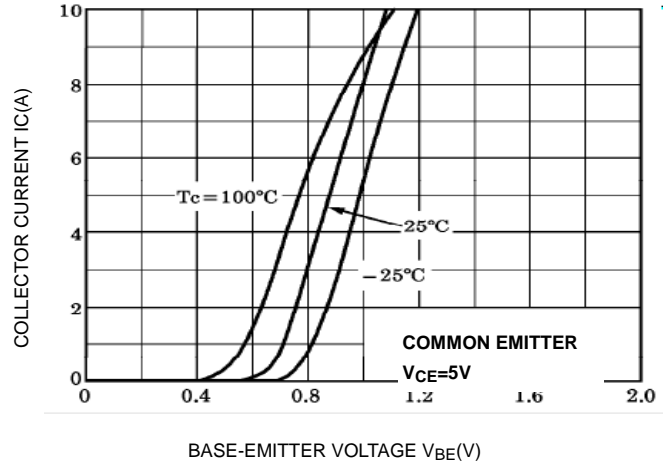

FIG-3  $V_{CE(sat)}$ - $I_C$  CHARACTERISTICS

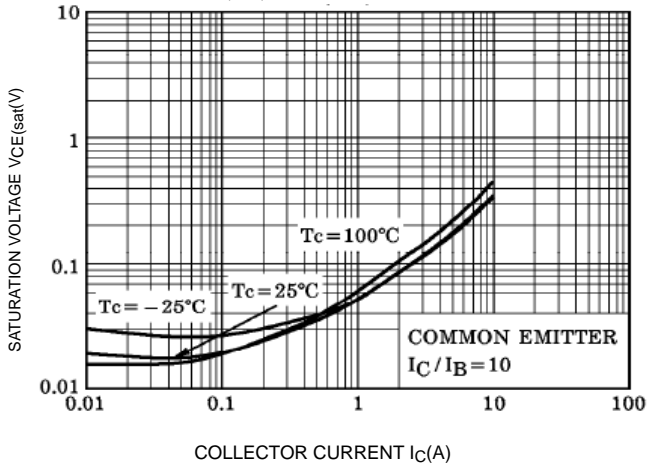

FIG-4  $h_{fe}$ - $I_C$  CHARACTERISTICS

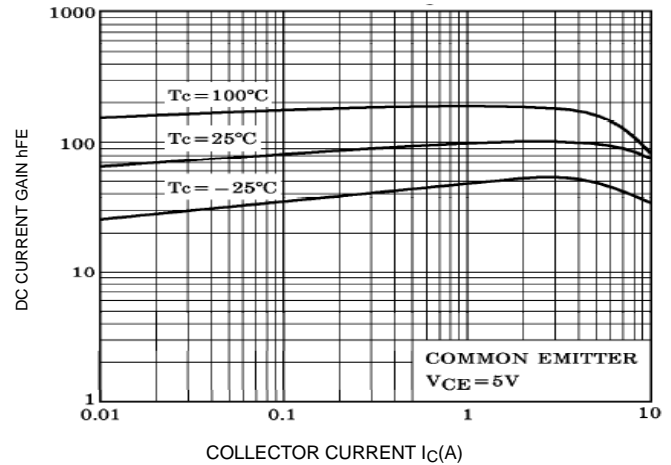
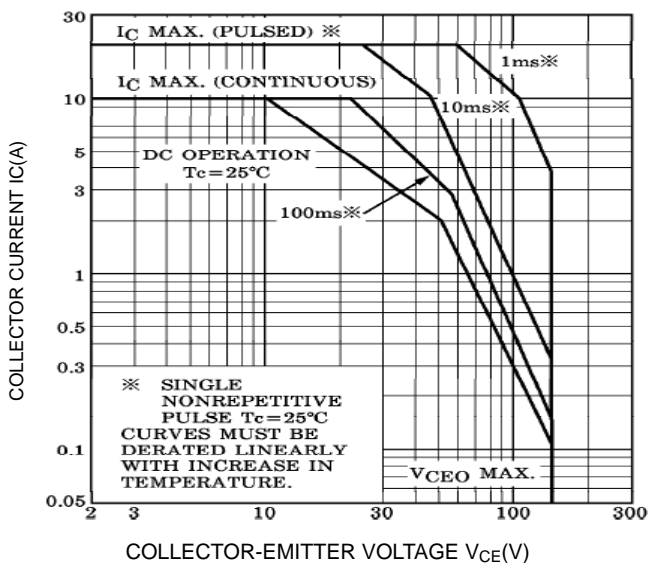
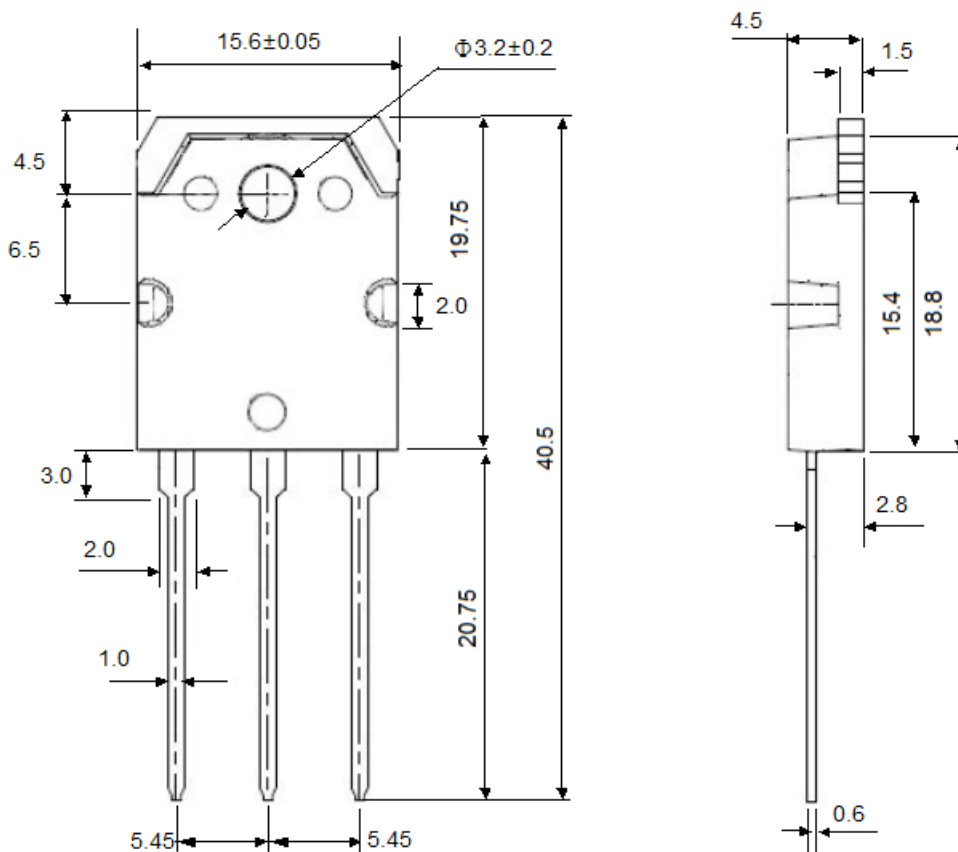

FIG-5 SAFE OPERATING AREA



### PACKAGE OUTLINE DIMENSIONS (Unit in mm)

#### TO-3PN



## Notice

MOSPEC reserves the rights to make changes of the content herein the document anytime without notification. MOSPEC or anyone on its behalf, assumes no responsibility or liability for any errors or inaccuracies. Please refer to MOSPEC website for the last document.

MOSPEC disclaims any and all liability arising out of the application or use of any product including damages incidentally and consequentially incurred.

Application shown on the herein document are examples of standard use and operation. Customers are responsible for comprehending suitable use in particular applications. MOSPEC makes no representation or warranty that such application will be suitable for the specified use without further testing or modification.

The information contained herein is presented only as a guide for the applications of our products. No responsibility is assumed by MOSPEC for any infringements of patents or other rights of the third parties which may result from its use. No license is granted by implication or otherwise under any patent or patent rights of MOSPEC or others.

These MOSPEC products are intended for usage in general electronic equipment. Please make sure to consult with MOSPEC before you use these MOSPEC products in equipment which require specialized quality and/or reliability, and in equipment which could have major impact to the welfare of human life ( atomic energy control, aeronautics , traffic control, combustion control, safety devices etc.)