

Product: 1.0SMB AU Series

Feature

- For surface mounted applications
- 1000W peak pulse power capability on 10/1000µs waveform
- Low incremental surge resistance, excellent clamping capability
- Very fast response time
- High temperature soldering guaranteed: 265°C/10 seconds
- Component in accordance to RoHS
- AEC-Q101

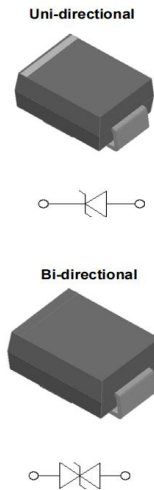

Dimension Figure

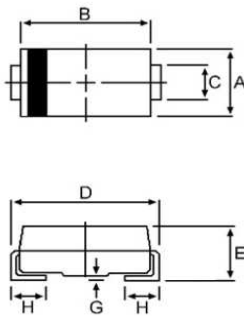

Dimensions	Millimeters		Inches	
	Min	Max	Min	Max
A	3.30	3.94	0.130	0.155
B	4.06	4.60	0.160	0.181
C	1.80	2.20	0.071	0.087
D	4.90	5.60	0.193	0.220
E	2.00	2.60	0.079	0.102
G	-	0.203	-	0.008
H	0.75	1.55	0.030	0.061

Maximum Ratings

Parameter	Symbol	Value	Unit
Peak Pulse Power Dissipation at T _A =25°C by 10x1000µs waveform	P _{PPM}	1000	W
Power Dissipation on infinite heat sink at T _A =50°C	P _{M(AV)}	5	W
Peak Forward Surge Current, 8.3ms Single Half Sine Wave	I _{FSM}	100	A
Maximum Instantaneous Forward Voltage at 0.2A for Unidirectional	V _F	1.2	V
Operating Junction and Storage Temperature Range	T _J , T _{STG}	-55 to 150	°C
Typical Thermal Resistance Junction to Lead	R _{uJL}	20	°C/W
Typical Thermal Resistance Junction to Ambient	R _{uJA}	100	°C/W

Electrical Characteristics

P/N		Marking		VR (V)	VBR @ IT (V)		IT (mA)	IR @ VR (μ A)		Ipp (A)	VC @ Ipp (V)
Uni	Bi	Uni	Bi		MIN	MAX		Uni	Bi		
1.0SMB6.8A-AU	1.0SMB6.8CA-AU	A10A	N10A	5.8	6.45	7.14	10	300	600	95.2	10.5
1.0SMB7.5A-AU	1.0SMB7.5CA-AU	A10B	N10B	6.4	7.13	7.88	10	300	600	88.5	11.3
1.0SMB8.2A-AU	1.0SMB8.2CA-AU	A10C	N10C	7.02	7.79	8.61	10	100	200	82.6	12.1
1.0SMB9.1A-AU	1.0SMB9.1CA-AU	A10D	N10D	7.78	8.65	9.55	1	40	80	74.6	13.4
1.0SMB10A-AU	1.0SMB10CA-AU	A10E	N10E	8.55	9.5	10.5	1	5	15	69	14.5
1.0SMB11A-AU	1.0SMB11CA-AU	A10F	N10F	9.4	10.5	11.6	1	3	4	64.1	15.6
1.0SMB12A-AU	1.0SMB12CA-AU	A10G	N10G	10.2	11.4	12.6	1	1	1	59.9	16.7
1.0SMB13A-AU	1.0SMB13CA-AU	A10H	N10H	11.1	12.4	13.7	1	1	1	54.9	18.2
1.0SMB15A-AU	1.0SMB15CA-AU	A10I	N10I	12.8	14.3	15.8	1	1	1	47.2	21.2
1.0SMB16A-AU	1.0SMB16CA-AU	A10J	N10J	13.6	15.2	16.8	1	1	1	44.4	22.5
1.0SMB18A-AU	1.0SMB18CA-AU	A10K	N10K	15.3	17.1	18.9	1	1	1	39.2	25.5
1.0SMB20A-AU	1.0SMB20CA-AU	A10L	N10L	17.1	19	21	1	1	1	36.1	27.7
1.0SMB22A-AU	1.0SMB22CA-AU	A10M	N10M	18.8	20.9	23.1	1	1	1	32.7	30.6
1.0SMB24A-AU	1.0SMB24CA-AU	A10N	N10N	20.5	22.8	25.2	1	1	1	30.1	33.2
1.0SMB27A-AU	1.0SMB27CA-AU	A10O	N10O	23.1	25.7	28.4	1	1	1	26.7	37.5
1.0SMB30A-AU	1.0SMB30CA-AU	A10P	N10P	25.6	28.5	31.5	1	1	1	24.2	41.4
1.0SMB33A-AU	1.0SMB33CA-AU	A10Q	N10Q	28.2	31.4	34.7	1	1	1	21.9	45.7
1.0SMB36A-AU	1.0SMB36CA-AU	A10R	N10R	30.8	34.2	37.8	1	1	1	20	49.9
1.0SMB39A-AU	1.0SMB39CA-AU	A10S	N10S	33.3	37.1	41	1	1	1	18.6	53.9
1.0SMB43A-AU	1.0SMB43CA-AU	A10T	N10T	36.8	40.9	45.2	1	1	1	16.9	59.3
1.0SMB47A-AU	1.0SMB47CA-AU	A10U	N10U	40.2	44.7	49.4	1	1	1	15.4	64.8
1.0SMB51A-AU	1.0SMB51CA-AU	A10V	N10V	43.6	48.5	53.6	1	1	1	14.3	70.1
1.0SMB56A-AU	1.0SMB56CA-AU	A10W	N10W	47.8	53.2	58.8	1	1	1	13	77
1.0SMB62A-AU	1.0SMB62CA-AU	A10X	N10X	53	58.9	65.1	1	1	1	11.8	85
1.0SMB68A-AU	1.0SMB68CA-AU	A10Y	N10Y	58.1	64.6	71.4	1	1	1	10.9	92
1.0SMB75A-AU	1.0SMB75CA-AU	A10Z	N10Z	64.1	71.3	78.8	1	1	1	9.7	103
1.0SMB82A-AU	1.0SMB82CA-AU	B10A	O10A	70.1	77.9	86.1	1	1	1	8.8	113
1.0SMB91A-AU	1.0SMB91CA-AU	B10B	O10B	77.8	86.5	95.5	1	1	1	8	125
1.0SMB100A-AU	1.0SMB100CA-AU	B10C	O10C	85.5	95	105	1	1	1	7.3	137
1.0SMB110A-AU	1.0SMB110CA-AU	B10D	O10D	94	105	116	1	1	1	6.6	152
1.0SMB120A-AU	1.0SMB120CA-AU	B10E	O10E	102	114	126	1	1	1	6.1	165
1.0SMB130A-AU	1.0SMB130CA-AU	B10F	O10F	111	124	137	1	1	1	5.6	179
1.0SMB150A-AU	1.0SMB150CA-AU	B10G	O10G	128	143	158	1	1	1	4.8	207
1.0SMB160A-AU	1.0SMB160CA-AU	B10H	O10H	136	152	168	1	1	1	4.6	219
1.0SMB170A-AU	1.0SMB170CA-AU	B10I	O10I	145	162	179	1	1	1	4.3	234
1.0SMB180A-AU	1.0SMB180CA-AU	B10J	O10J	154	171	189	1	1	1	4.1	246
1.0SMB200A-AU	1.0SMB200CA-AU	B10K	O10K	171	190	210	1	1	1	3.6	274
1.0SMB220A-AU	1.0SMB220CA-AU	B10L	O10L	185	209	231	1	1	1	3.0	328
1.0SMB250A-AU	1.0SMB250CA-AU	B10M	O10M	214	237	263	1	1	1	2.9	344
1.0SMB300A-AU	1.0SMB300CA-AU	B10N	O10N	256	285	315	1	1	1	2.4	414

Ratings and Characteristic Curves (TA=25°C unless otherwise noted)

Figure 1 - Peak Pulse Power Rating Curve

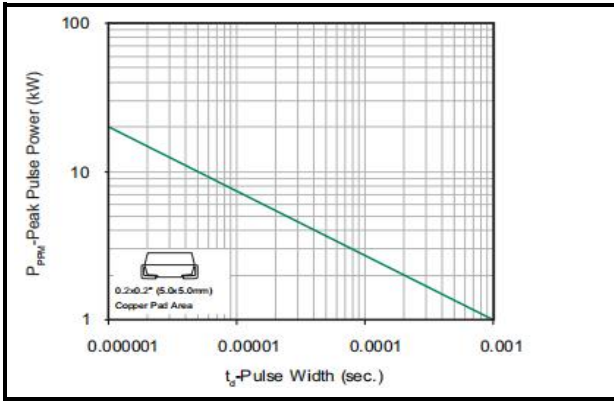

Figure 2 - Pulse Derating Curve

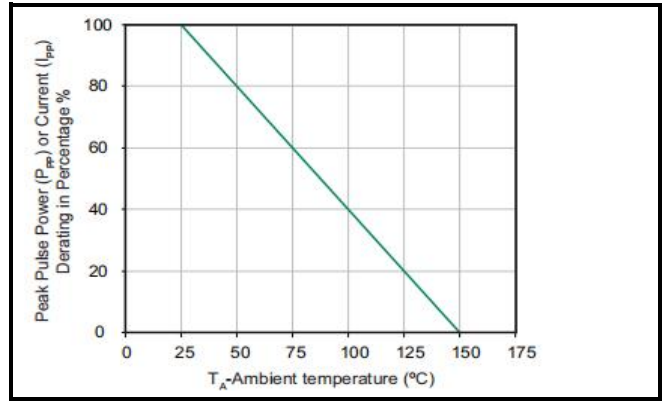

Figure 3 - Pulse Waveform

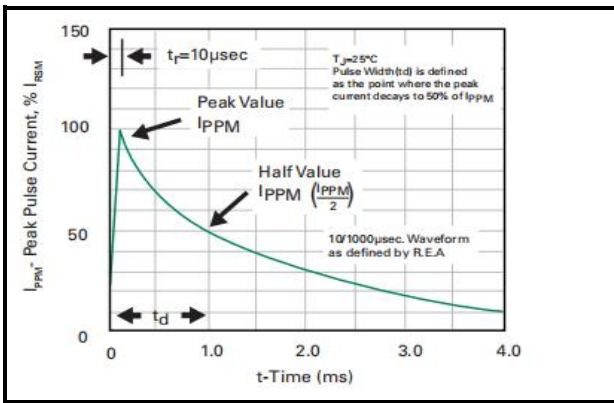

Figure 4 - Typical Junction Capacitance

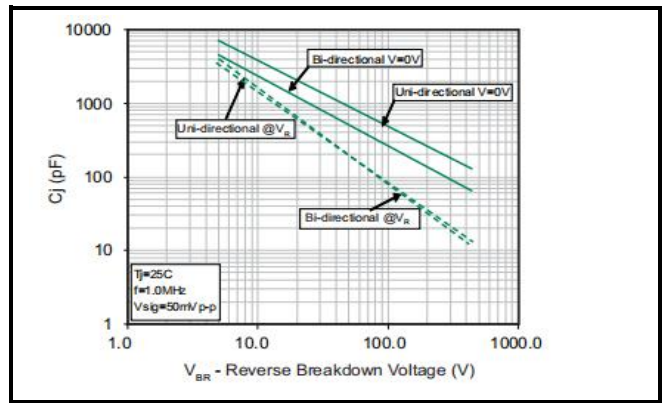

Figure 5 - Steady State Power Dissipation Derating Curve

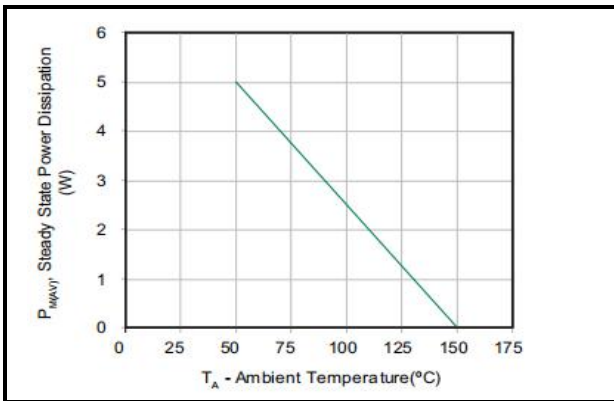
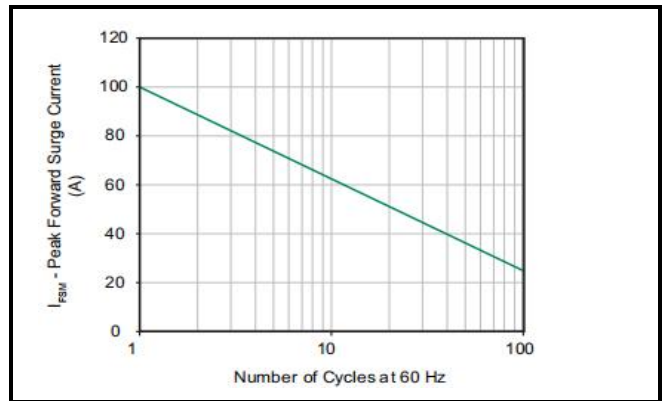

Figure 6 - Maximum Non-Repetitive Forward Surge Current Uni-Directional Only



Notice

MOSPEC reserves the rights to make changes of the content herein the document anytime without notification. MOSPEC or anyone on its behalf, assumes no responsibility or liability for any errors or inaccuracies. Please refer to MOSPEC website for the last document.

MOSPEC disclaims any and all liability arising out of the application or use of any product including damages incidentally and consequentially incurred.

Application shown on the herein document are examples of standard use and operation. Customers are responsible for comprehending suitable use in particular applications. MOSPEC makes no representation or warranty that such application will be suitable for the specified use without further testing or modification.

The information contained herein is presented only as a guide for the applications of our products. No responsibility is assumed by MOSPEC for any infringements of patents or other rights of the third parties which may result from its use. No license is granted by implication or otherwise under any patent or patent rights of MOSPEC or others.

These MOSPEC products are intended for usage in general electronic equipment. Please make sure to consult with MOSPEC before you use these MOSPEC products in equipment which require specialized quality and/or reliability, and in equipment which could have major impact to the welfare of human life (atomic energy control, aeronautics , traffic control, combustion control, safety devices etc.)